

Operator's manual



Basic machine City Ranger 3070

Applies to Software: 23053

Introduction

Dear Customer

Congratulations with your Egholm product. The City Ranger 3070 offers a very flexible way of maintaining areas.

Optimal use of your City Ranger 3070

To ensure optimal performance of your City Ranger 3070, please read this manual carefully before using the machine. Failure to do so can result in personal injury and damage to the machine.

Safety

The City Ranger 3070 is equipped with various devices to ensure optimal operational safety both for the user and their surroundings. We ask you to pay particular attention to section 1.1 Safety. The machine must only be driven by professionals in possession of driving license type B.

The City Ranger 3070 is designed only for use by professionals. On delivery, the user will receive thorough training to become a competent operator. Do not lend it to anyone who has not been thoroughly trained and who has not read this manual carefully. The operator's manual should be considered a permanent part of the machine and must remain with the machine if sold.

Warnings

Some items in this operator's manual are marked with this warning symbol, see figure 1. The warning indicates areas where extra care has to be taken to avoid personal injury or damage to the machine and its accessories. The warning also shows what you should pay special attention to.



Reservations

As it is the Egholm's policy to make continuous improvements, we reserve the right to alter the specifications and equipment at any time without notice. Egholm accepts no liability for errors or omissions in the operator's manual.

Contact us

Should you have questions of any kind regarding your Egholm product, please do not hesitate to contact Egholm.

Best regards

Egholm A/S

Transportvej 27 · DK-7620 Lemvig

Tel.: +45 97 81 12 05

www.egholm.eu - info@egholm.dk



Egholm app - easy access to useful material

Download our Egholm app, enter the serial number of your machine and possibly add attachments, and get access to videos, manuals, technical specifications and much more.

If you agree to receive notifications, you will be notified about product and service information, offers etc. The app is available for Apple and Android mobile phones.

Contents

Introduction	5
General information	7
1.1 Safety	7
1.2 Attachments	10
1.3 EC Declaration of Conformity	11
1.4 Technical data	12
1.5 Access to cabin	16
1.6 Controls	17
1.7 Alarm lights and monitoring indicators	24
1.8 Other controls	37
1.9 Electrical components	38
1.10 Driver's seat	43
1.11 Heating and air condition	44
1.12 Trailer	45
1.13 Towing	46
1.14 Mounting an attachment	47
1.15 Exhaust System (page 1.3)	48
Operator's manual	51
2.0 Operation modes	51
2.1 Transport mode	51
2.2 Work mode	51
2.3 Manuel mode	52
2.4 Daily operation	53
2.5 Cleaning and checking after each use	54
2.6 Fuel filling	55
2.7 Start, drive and stop	56
2.8 Engine warm-up	59
2.9 Transporting the City Ranger 3070	60
Service and maintenance	62
3.1 City Ranger 3070 service and maintenance chart	62
3.2 Engine oil	64
3.3 Hydraulic oil	66
3.4 Coolant	68
3.5 Brake fluid	70
3.6 Windscreen washer liquid	70
3.7 Lubrication	71
3.8 Filters	72
3.9 Checking belts	77
3.10 Changing a wheel	78
3.11 Checking for worn brakes	79
3.12 In case of failure	79
3.13 Storage	79
3.14 Valve Calibration	80
Conditions	82
4.1 Warranty	82
4.2 Complaints	83
4.3 Disposal	83

Introduction

**Honest
Machines**

City Ranger 3070

Achieve a higher efficiency and productivity by operating a strong and durable multi-function machine with an extensive flexibility. With the City Ranger 3070 you will get a compact multifunction machine with a high performance and optimum manoeuvrability. Among other things, this is provided by quality materials, articulated steering, easy operation, reliability and not at least excellent comfort. A full year equipment programme is at your disposal with several attachments. The professional attachments improve the function of the machine and are easy to handle.

Multipurpose utility machine

If you need a versatile and powerful machine, our City Ranger 3070 offers a wide range of possible attachments, suiting all year operation. Further, it provides you with a very fast and easy quick change system, which save you a lot of time. The City Ranger 3070 can be equipped with a full range of tailor made quality attachments - fully integrated and designed to work with the machine - ensuring high performance in every task.

Examples of tasks:

- Green care.
- Snow removal.
- Suction sweeping.

Comfort

The City Ranger 3070 is an utility machine with a spacious cabin equipped with air conditioning as standard. The cabin comes with an air suspended seat that is very comfortable and designed with a special armrest which as the seat is fully adjustable to suit the operator. All the operating controls are optimally positioned in the same place in order to ease the operation and optimize the overview for the operator.

Publication

This manual is made in accordance with the requirements in standard ISO 3600:1996. To order this manual please refer to this item number 55921946. This manual applies only to the City Ranger 3070.

General information

**Honest
Machines**

1.1 Safety

In this chapter safety instructions are described in order to ensure safe operation. Special attention should be taken to read and fully understand the content of this chapter. Any person who has not read and fully understood the content of this chapter must not be allowed to operate the City Ranger 3070.



Avoid roll-overs

Do not drive the machine in a place where it can slide, tip or roll. Use the machine on a solid and regular ground. Do not drive along slopes with an inclination of more than 5°. (Picture 1)

Maximum climbing ability 20°. (Picture 2)

Considerate driving is recommended.

The following situations are known to cause more instability in the machine and care should

be taken by the operator to assure safe operation:

- Emptying the hopper on an incline.
- Manoeuvring the machine with raised hopper.
- Abrupt steering.
- Manoeuvring with speed, on a slope or with weight on A-frame/B-frame.
- Manoeuvring with high speed in sharp turns.
- Manoeuvring the machine on an irregular ground.
- Low tyre pressure.



Avoid standing close to the machine while it is in use

Make sure that no person is near the machine while it is in use as there is a danger of collision. (Picture 3)



Do not inhale exhaust gas

Exhaust gas is hazardous to health and can even be fatal. If the machine is run in a confined space, the exhaust gas must be adequately ventilated out of the room or area, using an exhaust hose, for example. Otherwise doors and windows must be opened to allow fresh air inside.



①

Max.5°

Do not drive along on slopes with an inclination of more than 5°

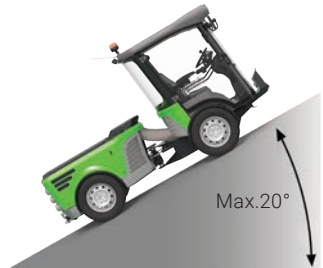

②

Max.20°

Maximum climbing ability 20°

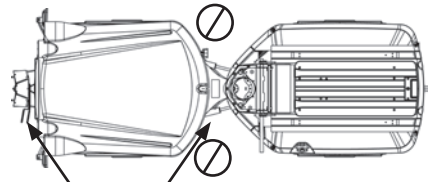

③

A-frame B-frame

Prevent people from standing in the working area

General information

1.1 Safety - continued



Avoid crushing

Make sure that nobody puts their hands, feet or any limb close to the mobile or articulated parts of the vehicle.



Exhaust pipe line

Do not touch the exhaust pipe line and the DOC/DPF (Diesel Oxidation Catalyst/Diesel Particle Filter) as it becomes very hot when the machine is running. (Picture 1)



Hydraulic components

Be aware that the hydraulic components may get hot when the machine is in use.



Mount/Dismount of attachments

Mount or dismount attachments on a flat or stable ground only.



Other hazards

There may be other circumstances and situations than those mentioned above where it may be dangerous to use the City Ranger 3070.

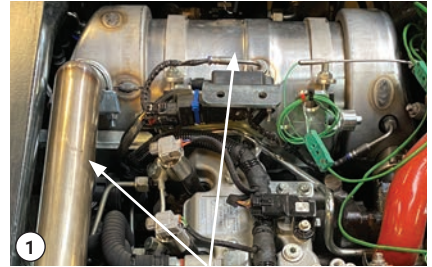

Exhaust pipe line and DOC/DPF (Diesel Oxidation Catalyst/Diesel Particle Filter)

Take care while handling potentially dangerous products

- Do not smoke when filling up.
- Do not spill diesel on the engine, the mechanical parts or the vehicle body.
- The brake fluid is very harmful and very corrosive. Avoid contact with the skin and eyes. In case of contact, rinse thoroughly with clear water. Any part of the vehicle in contact with the brake fluid should be rinsed out with clear water to avoid corrosion.
- The acid contained in the battery is very harmful and very corrosive. Avoid contact with skin and eyes. In case of contact, rinse thoroughly with clear water.
- In case of critical injuries, seek medical help.

General information

1.1 Safety - continued

Environment

Please consider the environment when any of the various fluids (brake liquid, battery liquid, hydraulic fluid, diesel, oil, and cooling water) should be discharged. Always discharge in accordance with local regulations.

Operation instructions



- Always watch out for the traffic while operating the machine.

- The City Ranger 3070 belongs to the category of public work vehicles. This vehicle should not be used for the transport of humans or goods.

- Climbing pavements is possible up to 15 cm from the ground (traditional pavements) and should be done very slowly.
- Remove the ignition key when leaving the machine in order to avoid unauthorized use.
- If the machine is parked long term the main switch should be disconnected to conserve battery power.

Maintenance

Egholm is by no means responsible for damages or accidents caused by misuse or by a lack of maintenance of the vehicle. When non-original spare parts are used, or attachments or other components are used which are not approved by Egholm, the guarantee will not apply.



• Only work in the engine compartment when engine is turned off and cooled. Keep a safe distance and wear safety glasses.

• Never put your hands in or near the cooling fan when it is running. (Picture 1)

Safety signs

The machine is equipped with two safety signs located in the articulation joint on the front frame. One on each side. The sign says that activities around the articulation point are forbidden.

The sign must be kept clean and visible at all times. If the sign is missing or illegible, it is the owner's responsibility to ensure that it is replaced. For ordering replacement please refer to item number E03001450. (Picture 2)



Cooling fan



Articulation joint warning

General information

1.2 Attachments

There is an operator's manual for each attachment. Operation with these attachments must follow the instructions outlined in the relevant operator's manual. Do not operate the City Ranger 3070 with the attachment unless all instructions have been followed.

City Ranger 3070 is designed to work with the following attachments, pay attention to maximum total weight and axle load - see page 12 point 1.4:

Attachment	Type
Suction sweeper.....	30SHBA_30FBBA
Weed brush	30WBAA
Rotary/mulch mower 1500.....	30LMBA
Triplex rotary mower 2500.....	TH2500B
Snow sweeper	30SSAB
Snow plough	FS1500M
Snow V-plough	PS1500MKV
Salt and sand spreader.....	30SGAA

1.3 EC Declaration of Conformity

Manufacturer: **Egholm A/S**
Address: **Transportvej 27 · DK-7620 Lemvig**
Telephone: **+45 97 81 12 05**

hereby declares that

Machine: **City Ranger 3070**
Type: **UHM3070B0**
:

has been manufactured in conformity with the provisions of Regulation (EU) 167/2013 and Directive 2006/42/EC.

Any alteration, rebuilding or addition of implements, accessories or other equipment not manufactured by Egholm automatically results in the cancellation of type approval, CE approval, any other approval, as well as any warranty on machine and attachments.

Unless otherwise agreed in writing between the operator, customer and Egholm, Egholm is the data originator (data originator) of all data generated by the machine and attachments during use.

Person authorized to compile the technical documentation:
Mr. Rainer Flanz
Egholm A/S
Transportvej 27 · DK-7620 Lemvig

Place: Lemvig
Date: _____
Signature: 
Rainer Flanz, R&D Manager

General information

1.4 Technical data

Location of type plate and serial number

Type plate is located on the front frame right side.

Serial number is located on the front frame above right hand steering cylinder.

Dimensions

Length (L).....	3.670 mm
Width (W) (Std. tires/Wide tires).....	1.220/1.285 mm
Height (H).....	2.000 mm
Height with beacon	2.210 mm
Wheel base	1.900 mm
Ground clearance (Suction pipe/Articulation).....	160/215 mm

Weight

Kerb weight without driver, incl. fuel	1.710 kg
Gross vehicle weight rating.....	3.000 kg
Payload.....	1.200 kg
Maximum vertical load on coupling point	100 kg
Permitted axle load, front.....	2.000 kg
Permitted axle load, rear.....	2.000 kg

Operating temperature

Temperature range *	From -18°C to 40°C
For operations.....	From -25°C to -18°C

Tyres

Standard: All year/winter (M+S*).....	195/75 R16
-Tyre pressure.....	4,85 bar
Wide tyre: Extra comfort	235/60R16
-Tyre pressure.....	3,3 bar
Grass/Turf tyre: Extra comfort & lower ground pressure	27x10.50-15
-Tyre pressure (BKT).....	Max. 6,4 bar
Winter tyre for snow chains: Winter (M+S*).....	195/70 R15
-Tyre pressure (Nexen)	4,85 bar

1.4 Technical data - continued

Refer to the engine operator's manual for further technical data.

* If the City Ranger 3070 has to operate in ambient temperatures below -15°C (5°F), you must warm up the machine slowly and change the hydraulic oil. See oil type in the section Service and Maintenance, Hydraulic oil.

Engine

Type/manufacturer.....	Perkins
Type.....	404J-E22TA
Cylinders	4
Displacement.....	2.200 cm ³
Maximum engine power.....	55 kW/74 hp*
Engine speed at maximum power.....	2.800 rpm
Maximum torque.....	270 Nm
Engine speed at maximum torque.....	1.600 rpm
Emissions	EU Stage V
.....	U.S. EPA Tier 4 Final

Fuel

Fuel tank capacity (Diesel)	50 l
-----------------------------------	------

* Temperature-dependent power regulation from 55 kW to 50 kW.

Lubricating system (std conditions)*

Total engine lub. system capacity (dry engine)	8 l - synthetic
Engine oil viscosity depends on the working temperature	
Engine oil specifications.....	API-CK-4, standard SAE10W-30

Cooling system (std conditions)*

Total coolant capacity (dry engine)	11 l - Antifreeze mixture
Antifreeze mixture.....	50% antifreeze - 50% soft water
Antifreeze specifications.....	Perkins ELC or ASTM D6210

* for high/low temperatures the data should be reviewed.

General information

1.4 Technical data - continued

Electrical system

Start system.....	Electrical starter with glow plugs
Alternator.....	12V-85A
Battery.....	12V-100AH-880A

Hydraulic oil (std. conditions)*

Total hydraulic system capacity (all system).....	Approx. 60 l-synthetic
Standard type.....	Texaco Rando HDE68

Brakes

Service brakes.....	Hydraulic drum brakes on front wheels
Parking brakes.....	Spring loaded brakes on rear wheels
Emergency.....	Hydrostatic braking

Driving

Speed forward.....	(40 km/h variant.....	Max. 40 km/h (25 mph)
.....	(25 km/h variant.....	Max. 25 km/h (16 mph)
Speed reverse.....	Max. 10 km/h (6 mph)

Air conditioning

Gas R 134a.....	425 g
Oil.....	SP10

* for high/low temperatures the data should be reviewed.

1.4 Technical data - continued

Noise level for City Ranger 3070

	Without window 25 km/h / 40 km/h	With window 25 km/h / 40 km/h
Outside noise, stationary, in accordance with VO (EU) 2018/985 Ann. II	72 dB(A) / 72 dB(A)	72 dB(A) / 72 dB(A)
Outside noise, in motion, in accordance with VO (EU) 2018/985 Ann. II	75 dB(A) / 76 dB(A)	75 dB(A) / 76 dB(A)
Inside cabin noise, in accordance with VO (EU) 1322/2014 Ann. XIII	67 dB(A) / 67 dB(A)	68 dB(A) / 68 dB(A)

Vibration test

Egholm can declare that if the machine is used according to these instructions, the vibrations do not cause dangerous situations.

Whole body, according EN1032-EN13059	0.25 m/s ²
Hand/Arm, according EN5349-EN12096	0.63 m/s ²

Seats mounted for vibration test: Grammer MSG75GL/522 Primo XXL or ISRI 6830K

Both seats are approved according Directive 78/764/EEC.

Cabin

Falling Object Protective Structure - FOPS

The City Ranger 3070 and its attachments do not operate when falling objects are a risk.

Roll-Over Protective Structure - ROPS

Tested according to Regulation (EU) 1322/2014 annex X, and fulfills OECD Code 7.

Contact with hazardous substances

The air intake contains a filter to protect the driver against dust inhalation.

Cabin classification according to EN 15695-1 is Category 1.

This cabin category does not provide protection against hazardous substances.

The City Ranger 3070 fitted with this cabin shall not be used under conditions requiring protection against hazardous substances.

Turning circle

Turning circle - kerb to kerb	4.120 mm
Turning circle - inside	1.650 mm

Information plate

Mounted on the right side of the front chassis.

Operating City Ranger 3070

There is no need for special tools to operate the City Ranger 3070.

Attention

Specifications may be changed without prior notice.

General information

1.5 Access to cabin

Access to the cabin is from the left side door. Push the button on the handle to open the door. (Picture 1)

Use the entrance step and door handle to get into the cabin. (Picture 2)

To leave the cabin, open the left door with the internal door handle. (Picture 3)

In the same way use the entrance step to leave the cabin.



Attention

There is a similar door on the right side. This door is operated in the same way as the left door and can be used as an emergency exit.



Attention

Always lock the machine when leaving. Never leave keys in ignition lock.



Attention

Keep the cabin free of loose items that may interfere with safe operation of the machine. Always store items in the storage box. (Picture 4)



Handle on the door



Entrance step



Internal door handle



Storage box (with cooling possibility)

1.6 Controls

Armrest controls

All controls are located in near range of the operator for optimum comfort and usability. The controls are built into the right armrest, the steering column, and into floor pedals.

In this chapter the controls and their functionalities are described.

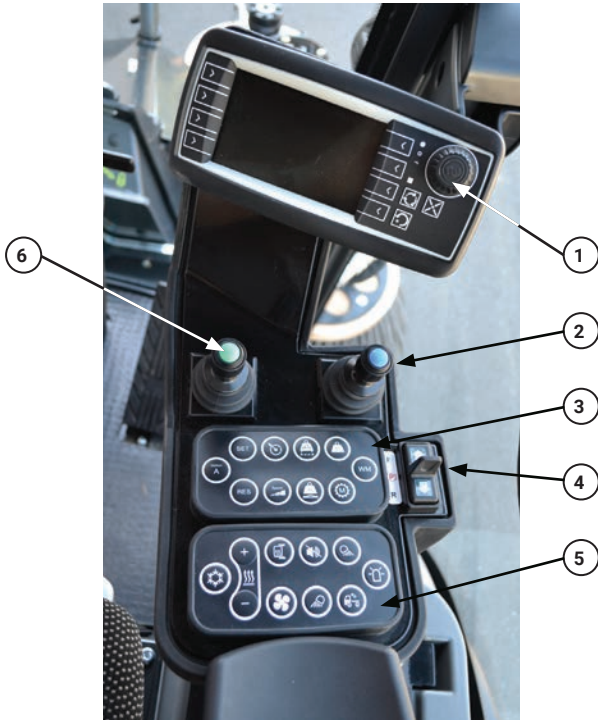

Arm rest controls

Armrest

1. Display.
2. Right joystick.
3. Keypad 1.
4. Direction switch (Forward, Parking, Reverse), (See 1.6 Controls, page 17).
5. Keypad 2.
6. Left joystick.

General information

1.6 Controls - continued



Steering column controls

Steering column

(Picture 1).

1. Multifunction switch.
2. Light switch (see Section 1.8).
3. Steering wheel.
4. Hazard light (see Section 1.8).
5. Ignition key.

Floor pedals

(Picture 2)
(see Section 1.8).

1. Drive pedal.
2. Inch/brake pedal.



2. Inch/brake pedal 1. Drive pedal

General information

1.6 Controls - continued

Joysticks

The machine has two joysticks mounted on the armrest to control the attachments and the A-frame. This section covers only the actuation of the A-frame as control of the attachments is covered in the manual of each attachment.

The right joystick controls the actuation of the A-frame. If the joystick is pushed in the forward direction, the A-frame will lower and if pulled reverse, the A-frame will lift up. (Picture 1)

When in workmode, and weight transfer or floating position is active. Pushing the right joystick forward or reverse will disengage the floating position or weight transfer. Reactivate by pressing the buttons on the keypad or push the right joystick all the way back/forward and click the blue button.

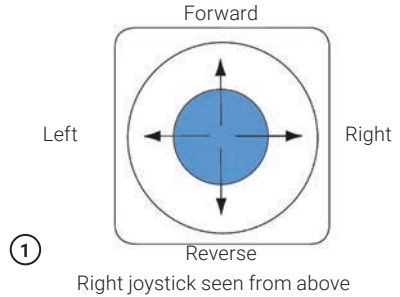

Direction switch

The direction switch controls the transmission. If the direction switch is pushed forward the machine will drive forward, the center position is parking and if pulled backwards, the machine will drive backwards. When in parking position, the parking brake automatically engages. When in forward or reverse the parking automatically disengages. (Picture 2)

Multifunction switch

1. Horn.
2. Washer fluid.
3. Direction indicator. Move the lever up to indicate right turn. Move the lever down to indicate left turn.
4. Windscreen wiper. Rotate one step for interval. Rotate 2 steps for full speed. (Picture 3)



Attention

Always ensure that washer fluid tank contains enough to satisfy the need for the trip. Beware that washer fluid does not freeze.

General information

1.6 Controls - continued

Keypad panels

The machine has two keypad panels. Their buttons and functionalities are described in this section.

Keypad 1

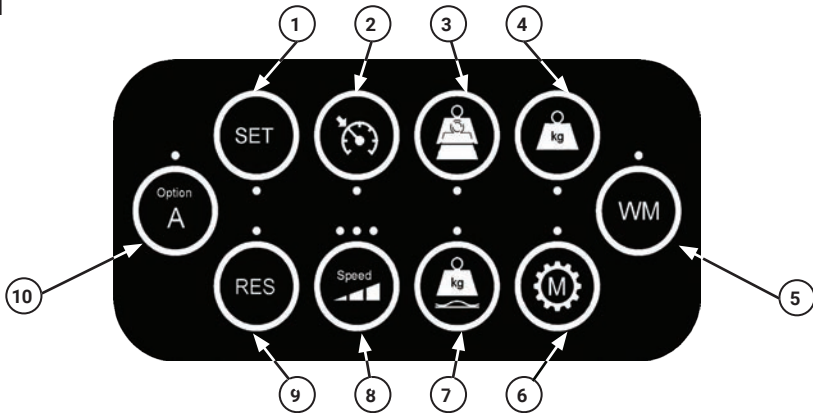

1. SET

Press to set current speed in cruise control. When in cruise control press to step up the speed.

2. Cruise control activation

Press this button to enable cruise control. The switch is also used to disable cruise control. The brake pedal can also be used to disable cruise control.

3. Load suspension

If load suspension is activated, the A-frame will dampen machine vibrations when driving with an attachment mounted. This helps to increase operator comfort. Load suspension can only be enabled in transport mode. If load suspension is enabled the diode next to the button is illuminated. Load suspension will automatically be disabled if right joystick is activated in either forward or reverse direction or if the operation mode is changed to work mode or manual mode.

4. Weight transfer

The operator can adjust the pressure of which the selected attachment is pressed against the road/ground by using the weight transfer functionality. This function is only applicable in work mode. When active, the diode next to the button is illuminated.

Weight transfer will automatically disable if right joystick is activated in either forward or reverse direction or if operation mode is changed to transport mode or manual mode.

5. Work mode

When a valid attachment combination is selected, it is possible to enable Work Mode by pressing the work mode button. When enabled, the diode next to the button is illuminated. In work mode controls appear to control the attachments selected and the machine is automatically configured to allow working instantaneously. The hydrostatic transmission is automatically adjusted to optimum performance for working with attachments. If the operator leaves the machine the engine is automatically stopped after 2 seconds for safety reasons. To disable work hydraulics press the Work Mode button briefly. To disable Work Mode completely press the button for 2 seconds.



1.6 Controls - continued

Keypad 1

6. Manual mode

Manual mode is used to allow the operator to safely leave the machine with the engine running in order to use external suction hose or high pressure washer. Manual mode can only be enabled if a hopper is mounted and the machine is set in parking. Disable Manual Mode by pressing the button again.

7. Floating position

In floating position the attachment is free to follow the contour of the ground. This function is only applicable in work mode. When active, the diode next to the button is illuminated. Floating position will automatically disable if right joystick is activated in either forward or reverse direction or if operation mode is changed to transport or manual mode.

8. Speed Limitation

Press to select speed level

1. level: 7 km/t
2. level: 15 km/t
3. level: 30 km/t

The number of illuminated diodes indicates which level is active. Using a low level renders the drive pedal less sensitive which makes the machine easier to control for low speeds. Only possible in Work Mode.

9. Resume

Press to resume cruise control last stored speed. When in cruise control press to step down the speed.

10. Option A

Depending on the attachment. See attachment manual.

Cruise Control

Cruise Control is specific for the mode the machine is in, and the steps up and down are done in percent.

So in work mode speed 1 driving max 7 km/h the steps are very small, making it easier to find the right speed.

When using cruise control in workmode, inching is active (see more chapter 1.8 inch/brake pedal)



General information

1.6 Controls - continued

Keypad 2

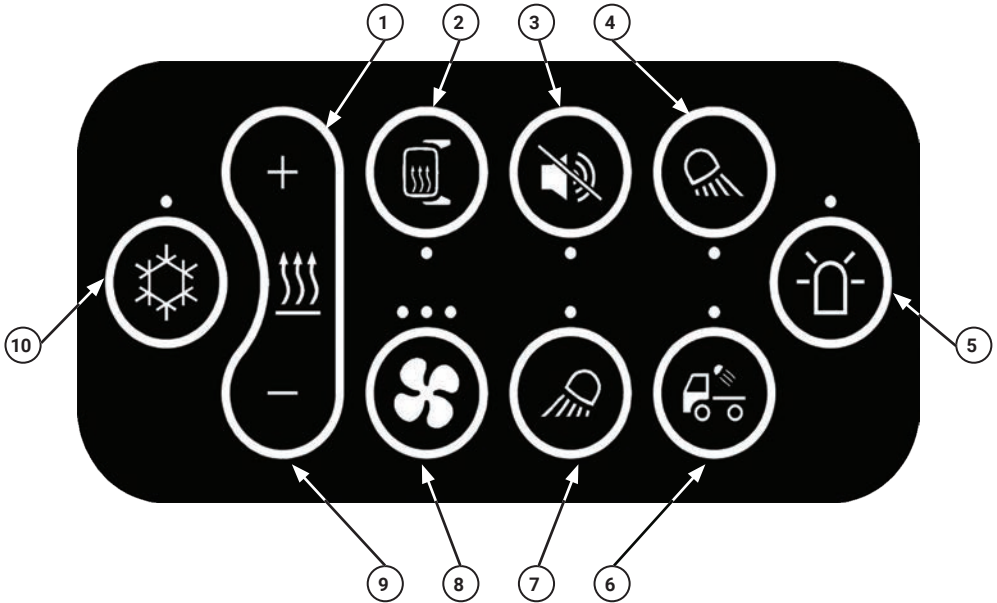

1. Heat increase

Press to increase cabin heat. Heat level ranges from 0 to 10. Level indication is available in the display.

2. Mirror heat (Option)

Press to turn on the mirror heat.

3. Reverse alarm off (Option)



Press to disable the reverse alarm.

Only disable when the noise is unacceptable and it is safe to disable.

4. Work light rear (Option)

Press to turn work light in the rear of the machine.

5. Beacon light (Option)

Press to activate beacon light.

6. Loading light (Option)

Press to activate loading light.

1.6 Controls - continued

Keypad 2

7. Work light front (Option)

Press to activate work light front.

8. Cabin fan

Press to turn on the cabin fan. Press again to increase the fan speed. There are 3 levels. The current level is indicated by the number of illuminated diodes next to the button.

9. Heat decrease

Press to decrease cabin heat.

10. Air condition

Press to activate the air condition. If the cabin fan is off before activating the air condition, the cabin will automatically be set to level 1.

General information

1.7 Alarm lights and monitoring indicators

Display and menus

Display keyboard

The display has some buttons that enable easy navigation between display menus and functionalities. (Picture 1)

1. Softkeys.
Select the functionality icon next to the particular softkey.
2. Encoder.
The encoder is used to both select and adjust bar graphs.
To select: push.
To adjust: turn.
To deselect: push again
3. Return one level.
This button returns the screen to the one previously shown.
4. Home.
This button returns the screen to the startup screen.

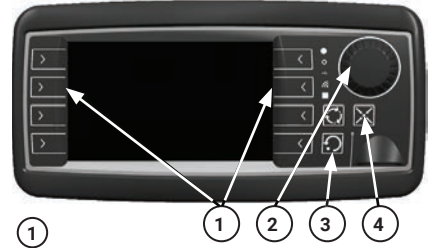

Display keyboard



Transport mode display screen

Transportation screen

When the machine is started, the transportation screen will appear. The transport mode display screen shows: (Picture 2)

1. Engine coolant temperature gauge.



Engine coolant temperature is 82°C when the needle is in vertical position. Operation is not recommended if the needle enters the red area.

2. Diesel fuel level.
3. Vehicle speed.
4. Transmission status.
F=forward, P=parking and R=reverse.
5. Cabin heat indicator.
6. Time.
7. Engine speed gauge.

General information

1.7 Alarm lights and monitoring indicators - continued

Display and menus

Menus

The machine has 6 menus. The menus to the left are related to configuration and troubleshooting. The menus to the right in the display are related to selection of attachments. (Picture 1)

1. Diagnosis
2. Settings
3. Information
4. Third party tools
5. Sweeping & vacuuming tools
6. Grass tools
7. Winter tools



①

Settings menu

General information

1.7 Alarm lights and monitoring indicators - continued

1. Error and technical menu (Picture 1)

1.1: Electrical info

1.2: Engine

- 1.2.1 Engine temperature (Picture 2)
- 1.2.2 Engine Diagnosis (Picture 3)
- 1.2.5 By pressing the button the cooling fan will turn around for 10 seconds.

1.3: Exhaust system

(more info on pages 48–49)

- 1.3.3 Exhaust Temperature (Picture 4)
- 1.3.4 Diesel Particle Filter status
- 1.3.4.7 DPF - Allow High Idle
- 1.3.4.8 DPF - Stop Regeneration in 30 minutes

1.4: Transmission status

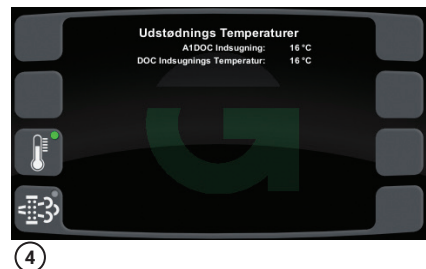
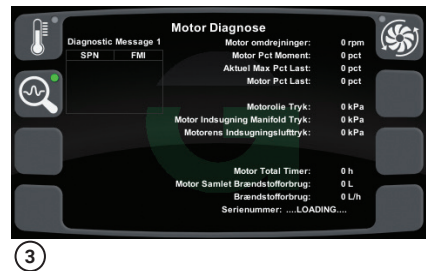
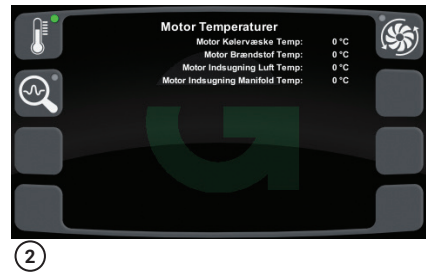

General information

1.7 Alarm lights and monitoring indicators - continued

1.5 :Joystick

- 1.5.6 Deadband adjustment (Picture 1)
- 1.5.7 Recalibration of Joysticks (Picture 2)
- 1.5.8 Joystick information (Picture 3)

1.6: Inch pedal

When properly calibrated is displayed "OK", when the brake / inch pedal is released. (Picture 4)

1.7: Valve error message

1.8: Temperature

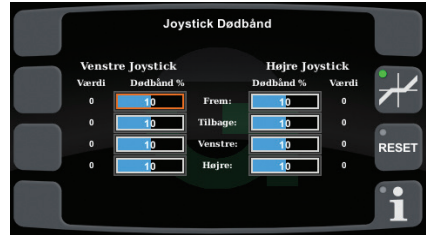

①



②



③

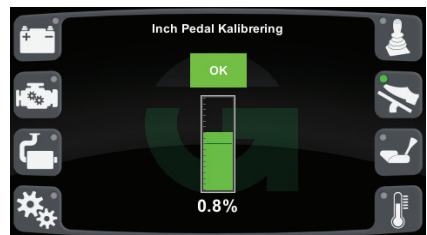

④

General information

1.7 Alarm lights and monitoring indicators - continued

2. Settings (Picture 1)

2.1 End of job lift enable/disable. If enabled the front tool will be lifted up when the machine leaves workmode.

2.2 Push to toggle between 12 or 24 hour clock.

2.3 Push to toggle between metric or imperial units.

2.4 A long press will increase hours and double click will increase minutes.

2.5 Push to select desired language.

2.6 Push to increase the display keyboard light. If the bar graph is at its maximum, another push will set the level to minimum.

2.7 Push to increase the keypad light. If the bar graph is at its maximum, another push will set the level to minimum.

2.8 Push to increase the screen light to desired level. If the bar graph is at its maximum, another push will set the level to minimum.

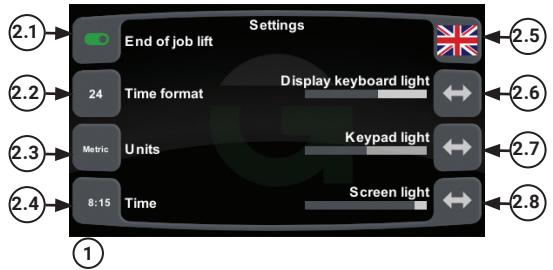

1.7 Alarm lights and monitoring indicators - continued

3. Information (Picture 1)

The information menu contains information about software versions and hours of operation. And information about if the comfort package is activated or not. The timer can be reset. (If the comfort package is paid for)



①

3.3 Log to USB

For Egholm Service & Diagnostics (visible when USB is attached).

3.4 Reset Timer

Only if comfort package is enabled

3.6 Machine options (Picture 1)

The purchased options are shown here! As well as the variant for the machine maximum speed!

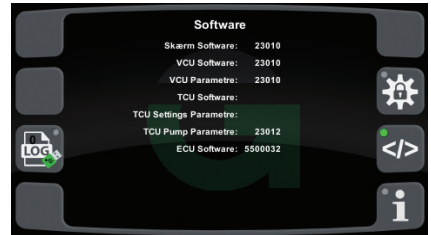

②

3.7 Software (Picture 2)

The current software and parameters on the engine, controllers and display.

3.8 Information (Picture 3)

The information menu contains information of the operating hours of the machine as well as operation hours of the engine. The timer can be reset. (if the comfort package is paid)



③

General information

1.7 Alarm lights and monitoring indicators - continued

4. More information

To find more information about the service selections, see the attachment manuals.

Description of speed 1,2 and 3 in Work mode

Display will show maximum speed

- Step 1: Maximum speed 7 km/t. (Picture 1).
- Step 2: Maximum speed 15 km/t. (Picture 2).
- Step 3: Maximum speed 30 km/t. (Picture 3).



①



②



③

1.7 Alarm lights and monitoring indicators - continued

Joystick calibration (1.5.7)

The calibration may be forgotten and an error light may be displayed. If the machine has been without battery for a long time.

If one or more arrows are RED, calibration is required.

If all arrows are GREEN, calibration should not be necessary, but if the calibration does not seem to be OK, you can calibrate by simply following the steps below.

1. Press the softkey next to the green arrow until you hear a beep.
2. Hold both joysticks in all outer positions for 3 seconds, one joystick at a time. (Left -> Right) and (Forward -> Backward) until all arrows turns green. (Pictures 1 and 3)

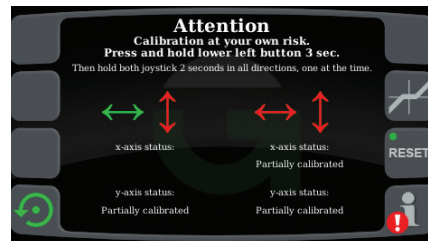
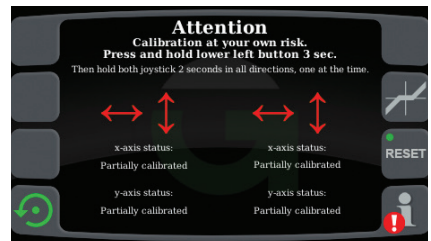

General information

1.7 Alarm lights and monitoring indicators - continued

Joystick "Deadband" (1.5.6)

Setting deadband in all directions for both joysticks. The default setting is 10, with this setting there still a small mechanical dead band.

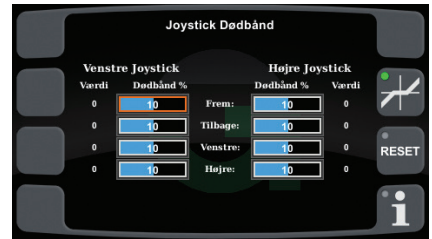

①

1.7 Alarm lights and monitoring indicators - continued

Warning and signal lights

The machine features several warning and signal lights. Their meaning and purpose are described in this section. Note any warning or signal light must not be ignored.



Attention

In case of engine overheating or of hydraulic overheating, contact your after-sales service. Do not open the radiator cap when the liquid is under pressure. There is a risk of accidents.

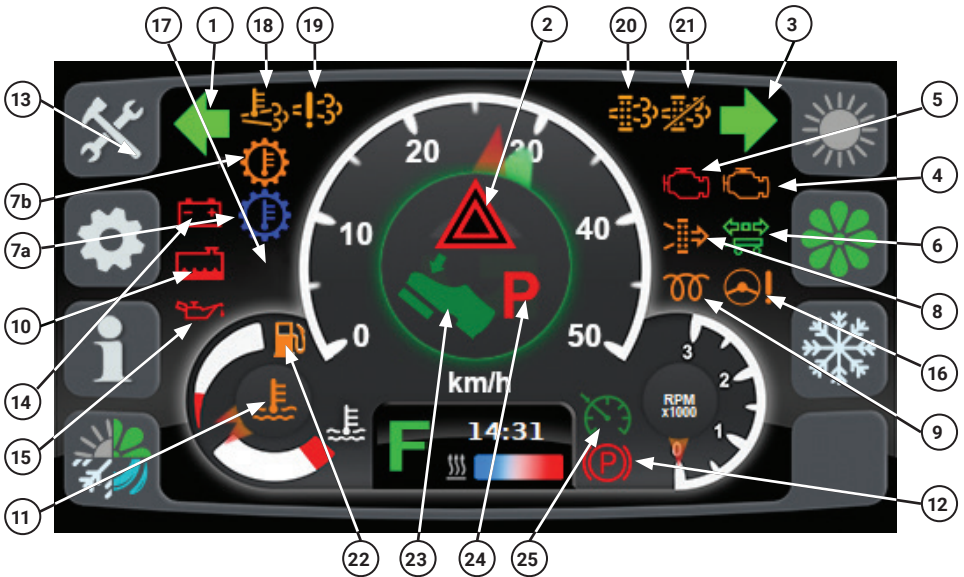

1. Left direction indication

Appears when the indicator arm points to the left or if the hazard switch is on.

2. Hazard light

Flashes when the hazard button is on along with the right and left indication arrows (1 and 3).

3. Right direction

Appears when the indicator arm points to the right or if the hazard switch is on.

4. Amber warning light

This signal lamp turns on when the engine control unit detects an error. Working must be interrupted immediately and the machine driven to an authorized repair shop. When the amber warning light is turned on, you will hear 1 second beep.

General information

1.7 Alarm lights and monitoring indicators - continued

Warning and signal lights

5. Red engine fault

This signal lamp turns on when the engine control unit detects a critical error. All operation MUST be aborted immediately and the machine parked on the roadside as fast as possible. Failure to do so may cause severe damage to the machine and warranty is violated. If the red engine light is followed by a 10 second beep, phone authorized aftersales service for further instructions.

6. Trailer direction indication fault

Appears when a trailer is connected. Flashes if an error occurs. Check the trailer connector and trailer lights.

7a. Hydraulic oil LOW temperature alarm

If the hydraulic oil temperature is below 20°C this warning will appear solid. It is not possible to enter Workmode, until the temperature is above 20°C

7b. Hydraulic oil HIGH temperature alarm

If the hydraulic oil temperature exceeds 100°C this warning will appear solid. PTO front and rear will be deactivated to protect the machine. The warning will disappear, when the hydraulic oil temperature drops to 90 °C. It is recommended that the machine is allowed to cool when this warning appears. If blinking: The sensor is either defective and need to be changed, or there's a bad connection to it.

8. Clogged air filter alarm

Indicates that the air filter is clogged up with dirt and must be cleaned.

9. Pre-heating light

If this symbol appears, the engine is preheating. The engine will not start if the symbol is shown in the display.

10. Engine coolant level alarm

Appears if the engine coolant level is too low. Stop to investigate for leakages and refill engine coolant.

11. Engine coolant temperature alarm

Appears if the engine coolant exceeds 112 °C. PTO front and rear are deactivated to protect the engine. PTO front and rear resume when the temperature drops below 100 °C. It is recommended that the machine is allowed to cool when this warning appears.

1.7 Alarm lights and monitoring indicators - continued

12. Parking brake

Constant light indicates that parking the brake is active. If the light flashes, an error is detected. Contact authorized service technician.

13. Fault found

Follow the exclamation mark to locate the source of the error. Contact authorized service technician with this information.

14. Battery charge error

Indicates that the battery is not charging. Drive home immediately and beware that the machine may stop without further warning.

15. Oil pressure alarm

Indicates if there is low oil pressure on the engine. If the alarm appears, drive to the side of the road and stop the engine. Call Egholm service technician for help.

16. Steering pressure sensor

Indicates if there is no steering pressure. If this alarm appears with the engine ON, the steering is faulty and a Egholm service technician must be called for help.

17. Hydraulic oil level low

Drive to the side of the road and turn off the engine.

Check for any leakage.

Check the hydraulic level glass, located on the rear right side of the machine

If there is oil, try to restart and wait 15 sec,

If the alarm do not reappear you can operate the machine again.

If the error accours again, call Egholm service technician for help.

If there is no oil, then refill before driving any further.

18. DPF regeneration is active

(See page 49 for more info)

19. Engine emision system malfunction

(See page 49 for more info))

20. DPF regeneration needed ASAP

(See page 49 for more info)

21. DPF regeneration deactivated by user

(See page 49 for more info)

General information

1.7 Alarm lights and monitoring indicators - continued

22. Diesel indicator

Orange: Less than 6 liters, Blinking: Error - Out of range.

23. Press the brakepedal

To turn on the engine, the brake pedal must be pressed.

24. Put the machine in Park

To turn on the engine, the FNR switch needs to be in park / neutral.

25. Cruise control activated

When cruise control is activated, you can press (set) to set current speed or use (res) for resuming last speed.

1.8 Other controls

Light and hazard switch

To activate the position light, press the light switch one step. One further step turns on the driving light. In case of emergency press the hazard switch. (Picture 1)

Pedals

Drive pedal

The drive pedal controls the speed of the machine. In manual mode the drive pedal can be limited by pressing the speed level button (1.6 Controls: Page 18, button 8 on keypad 1). (Picture 2)

Inch/brake pedal

Pressing the pedal will engage engine braking. If pressed further both engine brake and drum brakes are applied to achieve maximum braking performance. Inching is possible when in workmode and cruise speed is set. The set speed (green marker) will follow the inch pedal. If the inch pedal is pressed further down, the cruise control will deactivate.

Storage box

The cabin AC system is connected to the storage box so when the cabin AC is activated cooling inside the box is possible. If the cabin heating is active the nozzle inside the storage box can be closed. (Picture 3)



Attention

Test brakes on daily basis. City Ranger 3070 does not freewheel and sudden deceleration occurs if the drive pedal is released rapidly.



Light switch Hazard switch



Inch/brake pedal Drive pedal



Storage box (with cooling possibility)

General information

1.9 Electrical components

Fuses and main switch

Cabin power distribution box

(Picture 1)

The cabin fuses and relays are located in the compartment on the back of the cabin. Other things like the Vehicle Control Unit (VCU) and diodes are also placed there. To gain access remove the cover. The placement of the fuses and relays is shown in Picture 2.



Cabin back cover

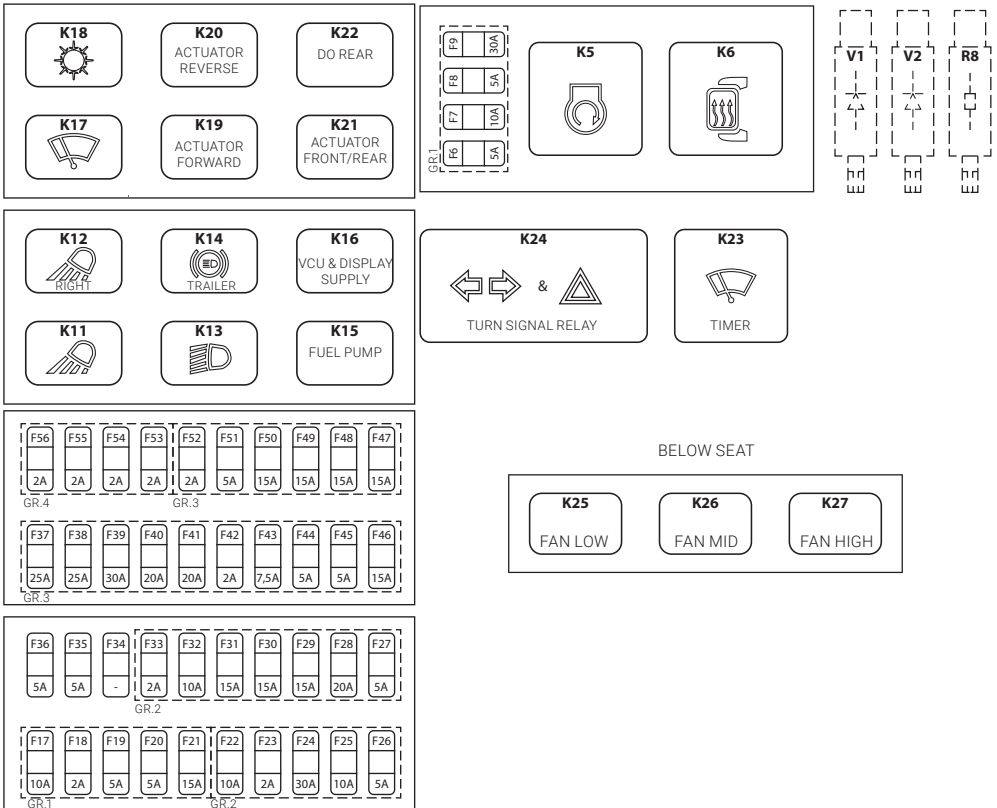

2

Cabin power box

1.9 Electrical components - continued

Cabin fuses, relays and diode functions

Fuse	A	Function
F6	5	Main Relay ECU Coil
F7	10	Fuel Pump
F8	5	ECU Memory
F9	20	Starter
F17	10	Direction Indicator Relay
F18	2	Hazard Light Signal
F19	5	Relay VCU & Display
F20	5	Radio Memory & Cabin Light
F21	15	Steering Column (Key Switch, Position Light, Low Beam, Horn, Washer & Wiper)
F22	10	Stop Light Trailer
F23	2	Relay VCU & Display Coil
F24	30	VCU Output Supply 4 (Lights)
F25	10	A/C Compressor
F26	5	A/C Controller
F27	5	Antifrosting Thermostat
F28	20	Cabin fan
F29	15	Low Beam
F30	15	Work Light Left
F31	15	Work Light Right
F32	10	Wiper
F33	2	Sensor (Tachometer, Engine inlet air filter & Trailer plug switch)
F34	-	Empty

Fuse	A	Function
F35	5	Key Switch
F36	5	Fuel Pump Coil
F37	25	VCU Output Supply 1 (Valves)
F38	25	VCU Output Supply 2 (Valves)
F39	30	VCU Output Supply 3 (Valves)
F40	20	Mirror Heat
F41	20	Seat
F42	2	Seat Switch
F43	7,5	Radio & USB
F44	5	Monitor & Camera
F45	5	Armrest (Keypad & Direction switch)
F46	15	TCU (Stop & Reverse light)
F47	15	A-frame Connector
F48	15	B-frame Connector
F49	15	Actuator
F50	15	Digital Out Rear
F51	5	Service Connector
F52	2	Turn Signals
F53	2	Position Light Left
F54	2	Position Light Right
F55	2	License Plate
F56	2	Position Light A & B-frame

General information

1.9 Electrical components - continued

Cabin fuses, relays and diode functions

RELAYS	
Relay	Function
K5	Starter
K6	Mirror Heat
K11	Working Light Left
K12	Working Light Right
K13	Low Beam
K14	Stop Light Trailer
K15	Fuel Pump
K16	VCU & Display Supply
K17	Wiper Supply Relay
K18	A/C Compressor
K19	Actuator Forward
K20	Actuator Reverse
K21	Actuator Front/Rear
K22	Digital Output Rear
K23	Wiper Timer Relay
K24	Flasher Relay
K25	Fan Speed low
K26	Fan Speed middle
K27	Fan Speed high

DIODES	
Diode	Function
V1	VCU & Display Supply Activation - Hazard Light
V2	VCU & Display Supply Activation - Key

1.9 Electrical components - continued

Battery power distribution box

The main fuses and relays are located on the rear end of the machine in the battery compartment. The main switch is also located here. (Picture 1)

To gain access remove the side cover by turning the two lower finger screws a quarter of a turn and lift of the cover. (Picture 2+3)

The placement of the fuses and relays is shown in Picture 4.

Battery

When connecting or replacing the battery, be sure that the power cords are connected correctly to the battery terminals.

Be careful not to make any short circuit between the battery terminals.

Clamp the battery so it is well fixed and put on the terminal protection covers.



Battery compartment



Access to: Battery compartment



Fuses and relays

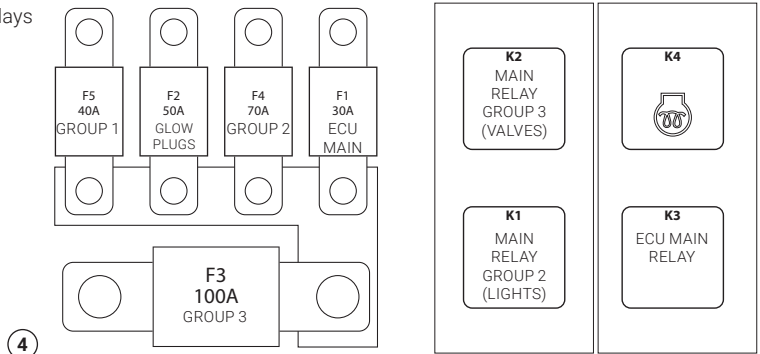

General information

1.9 Electrical components - continued

The rear end fuses and relays functions

Fuse	A	Function
F1	30	ECU Main Supply
F2	50	Glow Plug Supply
F3	100	Group 3 Supply (Key)
F4	70	Group 2 Supply (Key)
F5	40	Group 1 Supply (Battery)

Relay	Function
K1	Main Relay (Lights)
K2	Main Relay (Valves)
K3	ECU Main Relay
K4	Glow Plug Relay

Main Switch

It is only necessary to turn off the machine completely during transportation, longtime storage and maintenance. (Picture 1)
Wait min. 60 sec. after the engine is stopped before turning off the main switch.



Warning

Under no circumstances should the main switch be used during normal engine operation.

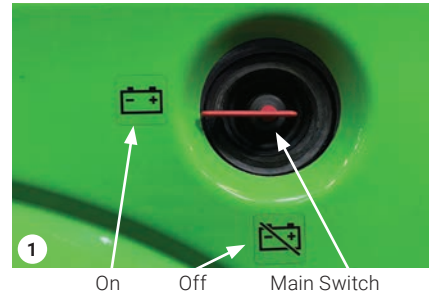

General information

1.10 Driver's seat



Attention

Adjust the seat to suit the operator before starting the machine.

Forward/backwards adjustment

Lift the locking lever and then move the seat to desired position. (1)

Weight

Adjust when the driver is sitting on the seat by pulling or pressing the lever (2). The seat is set correctly when the arrow is in the middle clear area of the viewing window. (Pictures 1+2)
Do not operate the lever for more than one minute in order to avoid compressor damage.

Backrest adjustment

Move the locking lever (4) upwards and adjust the backrest angle. When you have finished adjusting the backrest, the locking lever must be locked into the desired position.

Lumbar support

Adjust the curvature of the backrest cushion by turning the adjustment knob (3). (Picture 3)
0 = No curvature.

1 = Maximum curvature at the top.

2 = Maximum curvature at the bottom.

Steering column

Release the handle (5) to adjust the position of the steering column.
The foot pedal is used to tilt the steering column for easy access to the City Ranger 3070 (6). (Picture 4)



Attention

Never drive without fastened seat belt.
Do not adjust the steering column while driving.



Seat overview

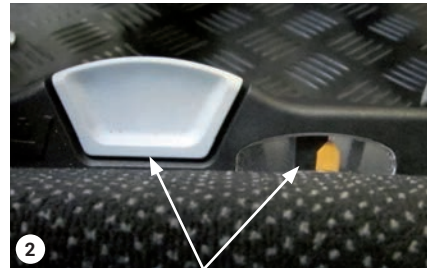

Weight adjustment



General information

1.11 Heating and air condition

Cabin heating

To switch on cabin heating, press the cabin heat increase button and turn on the cabin fan (Section 1.6, Keypad 2).

The cabin temperature can be adjusted in 10 steps and the fan in 3 steps for optimal comfort. The cabin heat level is shown in the display and the cabin fan speed is indicated by the diodes above the button. (Picture 1)

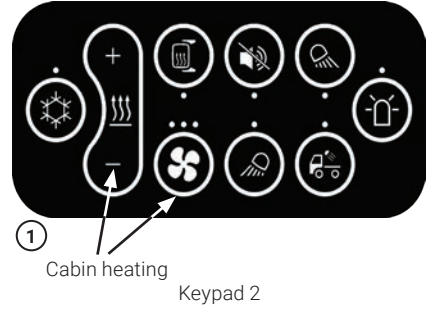

Air conditioning

To cool down the cabin, switch on the air conditioning and adjust the cabin fan speed on the keypad, located on the armrest.

NB: The air conditioning unit and the cabin filter must be checked/cleaned once a year

Cabin ventilation

The nozzles performing the ventilation are located at different places in the cabin (under the seat and under the roof). (Picture 2+3+4)

NB: To speed up the demisting of the windscreen, ensure that all nozzles located under the roof are fully open and directed at the windscreen. Turn on the AC and heat for fastest demisting

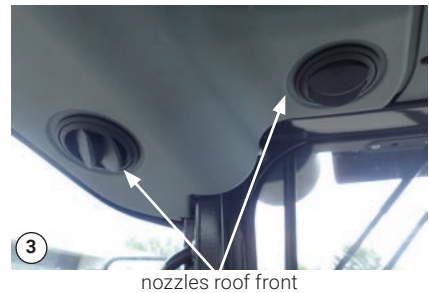
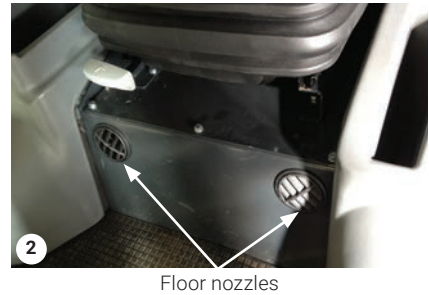

General information

1.12 Trailer

When the City Ranger 3070 is equipped with the approved coupling class A50-X, the following trailers can be connected:

- Trailers without brakes max. 750 kg.
- Gross vehicle weight with trailers without brake (vehicle + trailer + trailer load) max. 3.000 kg.
- Trailers with overrun brakes max. 2.000 kg.
- Vertical load on trailer coupling max. 100 kg.



Remark

A different coupling is not approved and guaranteed by Egholm



Remark

There is no brake assist system (brake line connection) for trailers on City Ranger 3070. Do not connect trailers with a brake assist system to City Ranger 3070.

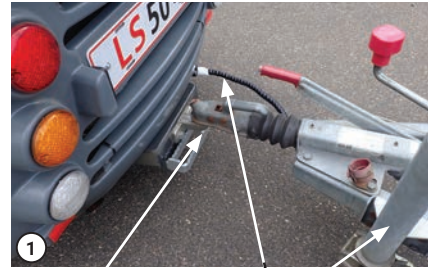

Connection lock

Support wheel

Electric plug

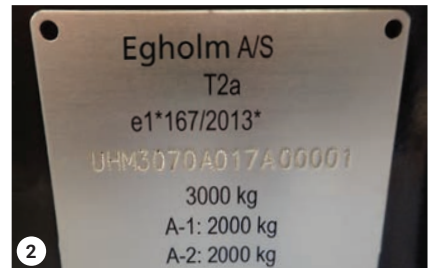

Type plate

Connecting trailers

Coupling: connect the trailer to the coupling and make sure that the connection lock is activated. Lift the support wheel on the trailer. (Picture 1)

NB: If the trailer is fitted with brakes, remember to attach the security wire on the trailer to the coupling

Lights

To control the lights of the trailer with the light switches in the cabin, connect the electrical plug on the trailer with the electrical socket on the City Ranger 3070. Check its function. (Picture 1)



Warning

Make sure that no one is standing between the machine and the trailer or near the working area.

General information

1.13 Towing



Warning

The City Ranger 3070 is a vehicle with a hydrostatic transmission. Avoid towing the machine for long stretches and at slowest possible speed, max.5 km/h (3.1 mph).



Warning

Release the parking brake before towing. The parking brake will activate automatically when Direction Switch is in P-position or if the engine stops.

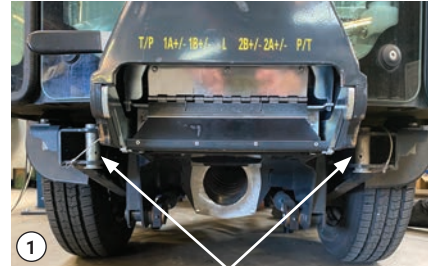

Front Towing device



Hydraulic pump valve

Pump lever

Release the parking brake

1. Remove the right side cover from the rear part of the machine.
2. Close the hydraulic parking valve.
3. Pump with lever, minimum 50 strokes.
4. It can be necessary to pump more strokes to keep the parking brake released. (Picture 2)

Towing the machine

Only tow the machine a few metres just enough to move it out of traffic.

1. Attach the towline to one of the towing devices. (Picture 1)
2. Release the parking brake.
3. Tow the machine slowly.

After towing, open the hydraulic Parking valve and mount the side cover again.

1.14 Mounting an attachment

Connecting and removing attachments

The engine must always be turned off before the attachment is connected/disconnected. Make sure that the couplings are clean before connecting. If not, carefully clean it with a cloth or similar.



Attention

The couplings and the area around the couplings must be kept clean to avoid an accumulation of dirt that could contaminate the hydraulic system. (Picture 1+2+3)

Mounting attachments

To mount or remove an attachment, refer to the operator's manual for the attachments. After mounting the attachment, make sure that the setting within the display keyboard matches the attachment mounted on the vehicle. Check display and chosen attachment(s) if not sure, before starting any operation.

Connecting a trailer with hydraulic tip (Option)

The hydraulic hoses are connected at the rear of the machine to the C-coupling. (Picture 3)



Attention

With a heavy attachment at the front of the City Ranger 3070 (eg: mower, snow sweeper), always drive carefully and take into account that there is a loss of grip on the rear wheels.



A-coupling



B-coupling

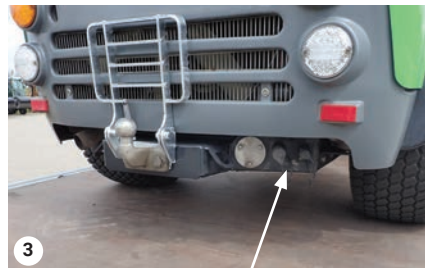

C-coupling

General information

1.15 Exhaust System (page 1.3)

DPF(Diesel particle filter) maintenance is performed continuously throughout the engine operation without the need of any operator interaction if the engine is being worked hard.

Status of the exhaust system will be shown on this page. When regeneration is needed there will be an indicator on the transport screen.

It's recommended that the user go to this page and activate regeneration.

If regeneration of the DPF (diesel particle filter) is needed, it will be shown on this page and how urgent it is. It will be possible if the regeneration is active to deactivate/inhibit it on this page for 30 min or until next cycle. The exhaust will become hot and can be a fire hazard if driving on dry grass, hay etc. In this case deactivating the regeneration is recommended.

1.15 Exhaust System (page 1.3) - continued



DPF regeneration is active:

The lamp will be on until regeneration has completed. Exhaust gasses will become very hot, keep the machine away from dry grass, hay etc.



Engine emission system malfunction:

Solid: Level 1 The yellow engine light will flash slow

Slow flash: Level 2 The yellow engine light will flash fast

Fast flash: Level 3 The yellow engine light will flash fast and the red engine light will be solid. 5 minutes cool down, Engine derate by 50% torque then shutdown or idle. Call Egholm service technician for help.



DPF regeneration needed ASAP:

Solid: Regen needed – highest level. Get the machine away from dry grass, hay. etc. and activate regeneration

Fast Flash: Regen needed – highest level. Get the machine away from dry grass, hay. etc. and activate regeneration. Soot load is very high, Regenerate ASAP.
If the yellow engine lights starts flashing, bring the machine to a stop immediately, and do a regeneration.
If the red engine lights also starts flashing, bring the machine to a stop immediately, and do a regeneration. Call Egholm service technician, machine needs a service test or a new DPF.



DPF regeneration deactivated by user:

This feature should only be used, if really needed. To reactivate do a cycle of the machine or press the inhibit button again

Operator's manual

**Honest
Machines**

2.0 Operation modes

The machine has 3 distinct operation modes:

- **Transport mode**

Use only for transportation of the machine between jobs.

- **Working mode**

Use this mode when attachments are mounted and the machine is at work site.

- **Manual mode**

Use this mode for working with external suction hose or high pressure cleaner. (Only applicable when the hopper is mounted. See manual for hopper for further information)



①

Transport mode display screen



②

Work mode button

2.1 Transport mode

Transport mode is the default operation mode and is solely used for transportation of the machine. When the machine is in this mode, the transport mode display screen is shown.

The hydrostatic transmission is adjusted to driving in public traffic.

If the operator leaves the machine and the direction lever is in either Forward or Reverse, the engine is automatically stopped after 2 seconds for safety reasons. (Picture 1)

2.2 Work mode

When a valid attachment combination is selected, it is possible to engage work mode by pressing the work mode button on keypad 1. When enabled the diode next to the button is illuminated. (Picture 2)

To disable work hydraulics, press the WM button briefly. To disable Work Mode completely, press the button for 2 seconds.

In work mode controls appear to control the attachments selected and the machine is automatically configured to allow working instantaneously. For more information regarding the controls please consult the manual for the attachments.

The hydrostatic transmission is automatically adjusted to fit working with attachments. If the operator leaves the machine the engine is automatically stopped after 2 seconds for safety reasons.



Work Mode disable

Operator's manual

2.3 Manuel mode

Manuel mode is used to allow the operator to safely leave the machine with the engine running in order to use external suction hose or high pressure washer.

Manual mode can only be engaged if following requisites are valid: (Picture 1)

- A hopper is mounted and selected in display.
- The machine is set in parking.
- Parking brake is active and without errors. Verify that the parking symbol is shown in the display.

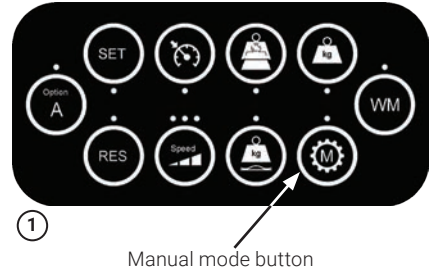

2.4 Daily operation

Daily checks before start-up

Walk around the vehicle and check:

- The state of the tyres and rims as the wheels are very exposed to jolts (pavements, edges, ...).
- The tyre pressure. (see Section 1.4)
- The state of your attachments.
- The ground under the vehicle in order to detect potential leakages, (diesel, oil, water..).
- The brake efficiency. Conduct one sequence of five abrupt brakings every day for brake maintenance.
- Check the engine oil level. (see Section 3.2)
- Check lights.
- Check if anything is out of the ordinary.
- Greasing points: see 3.7 Lubrication, page 56, greasing recommended at least every 50 hour.



Attention

Do not start up if the machine fails any of the above checks. Consult authorized service technician.

Operator's manual

2.5 Cleaning and checking after each use

Cleaning of the machine can be done with a high pressure cleaner kept at safe distance or a garden hose. Use an auto shampoo and soft brush to wash away dirt.



Attention

Do not spray cold water at hot parts of the machine.

Do not spray water into the engine compartment directly or through coolers or cooling fan.

Do not use any organic solvents.

Do not use high pressure washing on the cabin sealings, under the roof and around the doors.

Recommendation

Clean the machine on a regular/daily basis. Store tools and auto shampoo. Dose auto shampoo as described on the bottle.

2.6 Fuel filling



Attention

Always stop the engine before refueling. Carry out refueling outside or in a well-ventilated area. Avoid flames and sources of ignition. Diesel oil is highly flammable.

Diesel fuel

Use only the fuel diesel in accordance with the allowed fuel specification for this engine, listed following:

- Fuel diesel EN590.
- Fuel diesel ASDM D975 GRADE 1D S15.
- Fuel diesel ASTM D975 GRADE 2D S15.
- Fuel diesel JIS K2204.
- Fuel diesel BS 2869 or equivalent.

Important when refueling

- Keep the area free from dirt when filling.
- Do not overfill your fuel tank.
- Do not spill diesel oil.
- Do not smoke.

Fuel level is shown on the fuel gauge in the display.

The fuel tank cap is located on the left hand side. Open it using the proper key. (Picture 1)



Fuel cap

Operator's manual

2.7 Start, drive and stop

Rules to follow while driving

(Section 1.1 Safety, page 7)

- Any person using the vehicle must be sufficiently trained for using and handling the City Ranger 3070.
- Do not drive on a gradient steeper than 20°.
- Always drive carefully.
- Do not forget that the City Ranger 3070 is a relatively high and narrow vehicle. Turning should therefore be done at a low speed.
- Do not let the engine run in a closed area: there is a risk of asphyxiation.
- The braking distance of your vehicle increases when the road is wet and/or when your vehicle is loaded.
- Be aware of the steering sensitivity and reactivity.
- Always put on the safety seat belt.
- Never drive with an open door.
- If an alarm lamp is on or flashing when driving, please stop in a safe place and refer to this manual. (see Section 1.7)
- Always adhere to local traffic legislation.

Before starting the vehicle, the following conditions must be met

- The driver must sit on the seat.
- Direction switch must be in parking.
- Brake pedal must be activated.

It is advised to wait to drive until the display is turned on. If the main switch has been turned off, it takes approximately 21 seconds otherwise it will happen momentarily.

2.7 Start, drive and stop - continued

Starting and driving the City Ranger 3070

1. Put the Direction switch in the Parking position and push down the brake pedal.

If start is attempted in forward or reverse, it is necessary to turn the key to off position and wait for 5 seconds before another attempt is made. (Picture 1)

2. Turn the ignition key (clockwise) until the preheater indicator and other indicators light up. Once the pre-heater light goes out, the ignition key can be turned further to start the engine. (Picture 2)

3. After startup: Check that no warning light is on.

4. Put the Direction switch in either forward (F) or reverse (R). Parking brake is automatically released when the Direction switch is set to F or R. Likewise automatically engaged in parking (P).

5. Press on the drive pedal to achieve desired speed. (Picture 3)

Note: When the machine is in transport mode, the drive pedal controls engine rpm. In work mode the engine rpm is fixed.

Braking

For braking, there are two possibilities:

1. Slowly release the drive pedal (engine brake). It is a hydraulic brake that directly acts on the wheel motors.

2. Press on the Inch/brake pedal beyond the inching range to activate drum brakes. Here both engine brake and drum brakes are engaged to achieve maximum braking power.

3. The parking brake will automatic be activated when the Direction switch is in the P-position and the speed is below 2 km/h (1.2 mph).



Direction switch



Ignition key



Inching/brake pedal Drive pedal

Operator's manual

2.7 Start, drive and stop - continued

Turning off the City Ranger 3070

- Put the Direction switch in P-position.
- Turn off the City Ranger 3070 by turning the ignition key back to the key-release position (counterclock-wise).
- When the key is in key-release position, the key can be removed.



Remark

When the Direction switch is in P-position, the parking brake will activate automatically.



Attention

Check that the parking brake indicator is shown in the display. (Picture 1)



Attention

When the engine is OFF, the parking brake will activate automatically.



①

Parking brake

2.8 Engine warm-up

Warm-up instructions

- Do not attempt to start the City Ranger 3070 when the temperature is below -20°C.
- Start the engine.
- The pumps start up with the diesel engine and must be operated for at least 10 minutes at the engine idling speed in order to ensure self-lubrication.
- Then slowly operate all system functions several times at low load in order to warm up the entire system as uniformly as possible. In the same time slowly swivel the traction pump outwards. Continuous flushing is necessary in all components in order to prevent temperature shocks. All system functions must be operated slowly several times at low load until the entire system reaches a temperature where the machine works at full performances.

Operator's manual

2.9 Transporting the City Ranger 3070

To transport the vehicle, use the restraint straps and attach them to the two transport securing rings in front, and the two anchor brackets at the back. (Picture 1+2+3+4)



Attention

- Remember to secure doors, panels etc. before transport and taking off.
- Eventually reverse the machine on to the trailer for better weight distribution between vehicle and trailer.



Anchoring at the front

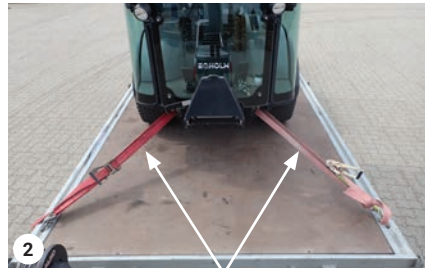

Straps at the front



Anchoring at the rear, two anchor brackets



Straps at the rear

Service and maintenance

**Honest
Machines**

Service and maintenance

3.1 City Ranger 3070 service and maintenance chart

X Lubricate

◆ Clean

● Replace

○ Check

Operation	Service schedule										
	Daily	First 50h	Every 50h	Every 500h	Every 1000h	Every 1500h	Every 2000h	Every 3000h	Every year	Every 2. year	See §
Machine											
Walk-around inspection	○										3.8
Tyre Pressure		○	○	○					○		1.4
Wheel bolts		○		○					○		-
Cabin Filter				●					●		3.8
Door adjustment		○		○					○		-
Battery (8)				○					○	●	-
Brakes		○		○/X					○/X		-
Brake fluid (5)		○		○				●	○	●	3.5
A-frame connections (4)	◆										-
B-frame connections (4)	◆										-
Lights	○										-
Retighten screws in articulation joint.		○		○							
Engine											
Air filter, main (3)		○/◆	○/◆	●					●		3.8
Air filter, safety (3)		○/◆	○/◆	●					●		3.8
Engine Oil (2)	○	○		●					●		3.2
Engine Oil filter (2)				●					●		3.2
Fuel filter, main				●					●		3.8
Fuel filter, decanter		○	○	●					●		3.8
Belt, Alternator		○		○	●				●		3.9
Coolant (1)		○	○	○				●	○	●	3.4
Coolant hoses and collars		○		○					○		-
Coolant temperature regulator (8)									●		-
Water Radiator (3)	◆	○		○/◆					○/◆		-
Water Radiator pressure cap				○					○		-
Engine water pump (8)									○		-
Engine fan clearance				○					○		-
Engine mounts (8)							○		○		-
Turbo charger (8)					○						-
Air Intake pipe /clamp bands				○	○				○		-
Breather tube				○	○				○		-
Engine crankcase breather						●					-
Fuel pipe / Clamps				○	○				○		-

Service and maintenance

3.1 City Ranger 3070 service and maintenance chart - continued

X Lubricate

◆ Clean

● Replace

○ Check

Operation	Service schedule										
	Daily	First 50h	Every 50h	Every 500h	Every 1000h	Every 1500h	Every 2000h	Every 3000h	Every year	Every 2. year	See §
Engine - Continued											
Glow plugs (8)								●			-
Starter (8)							○				-
EGR valve cleaning and ECU reset (9)								●			-
Valve Clearance					○						-
Hydraulic											
Hydraulic oil (6)		○		○		●			○	●	3.3
Hydraulic oil filter (6)		●				●				●	3.8
Hydraulic oil cooler	◆	○		◆					◆		-
PTO pressure relief valve				○					○		-
Hydraulic hoses		○		○					○		-
Air Condition											
AC hoses		○		○					○		-
Evaporator				◆					◆		-
Evaporator drain hose				◆					◆		-
Condensor				◆				◆	◆		3.8
Belt, A/C		○		○	●				●		3.9
Filter dryer, A/C									●		-
Lubrication											
Steering cylinder left		X	X						X		3.7
Steering cylinder right		X	X						X		3.7
A-frame lift cylinder		X	X						X		3.7
A-frame lock/cable		X	X						X		3.7
Door hinge		X		X					X		3.7

- 1) Check glycol level every 500h and before winter.
- 2) Replace engine oil and filter every 500h and at least once a year.
- 3) If the machine is operated in a very hot or dusty environment, more frequent service may be necessary.
- 4) Clean all couplings with a clean cloth before mounting any attachment.
- 5) Replace Brake fluid every 3000h and at least every two years.
- 6) replace Hydraulic oil and filter every 1500h and at least every two years.
- 7) Clean the brakes and trim every 500h and at least once a year.
- 8) Preventive maintenance.
- 9) Service only done by Perkins, Contact local Perkins dealer.

Service and maintenance

3.2 Engine oil

Only use commercial oils that meet the following classifications:

- API CK-4.
- ACEA E9.
- ECF-3.

Standard: 10W-40

NB! Lubricating oil viscosity must be suitable for the ambient temperature range for the climate in which the machine is to operate

(Picture 1)



Attention

Always switch off the engine when checking the oil and when changing the oil and the oil filter.

Engine oil check

1. Park the City Ranger 3070 on a level surface.
2. Wait for at least 10 minutes after stopping the engine in order to allow the engine oil to return to the oil tank.
3. Take the dipstick out, dry and put back. (Picture 2)
4. Take the dipstick out again to read the oil level. The oil level must be between MAX. and MIN. on the dipstick. (Picture 2)
5. In case of lack of oil, remove the filler cap on the engine. Add oil, wait a few minutes and check the level again. (Picture 3)

	Minimum	Maximum
10W-40	-20 °C (-4 °F)	50 °C (122 °F)
SAE 0W30	-30 °C (-22 °F)	30 °C (86 °F)
SAE 0W40	-30 °C (-22 °F)	40 °C (104 °F)
SAE 5W30	-25 °C (-13 °F)	30 °C (86 °F)
SAE 5W40	-25 °C (-13 °F)	50 °C (122 °F)
SAE 10W30	-20 °C (-4 °F)	40 °C (104 °F)
SAE 15W40	-10 °C (14 °F)	50 °C (122 °F)

①

Viscosity according to temperature

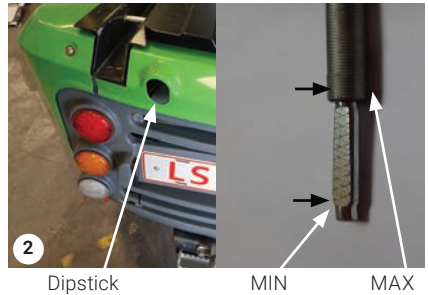

3.2 Engine oil - continued

Change of engine oil and oil filter

NB: Drain the crankcase when the oil is hot.



Attention

Hot oil and hot components can cause personal injury. Do not allow hot oil or hot components into contact with your skin.

1. Park the City Ranger 3070 on a level surface.
2. Open the filler cap. (Picture 1)
3. Remove the oil drain plug in order to allow the oil to drain in a drain pan. (Picture 2)
4. After drainage, clean the oil drain plug and put it back with a new gasket.
5. Remove the oil filter with a suitable tool. (Picture 3)
6. Clean the sealing surface of the cylinder block or the oil cooler.



Attention

Do not fill the oil filters with oil before installing them. This oil would not be filtered and could be contaminated. Contaminated oil can cause accelerated wear to engine components.

7. Apply clean engine oil to the new oil filter seal.
8. Install the new oil filter. Tighten the filter by hand. Do not overtighten the oil filter.
9. Fill the crankcase with the correct amount of oil. (approx. 10.6 litres)



Attention

Underfilling or overfilling the crankcase with oil can cause engine damage.

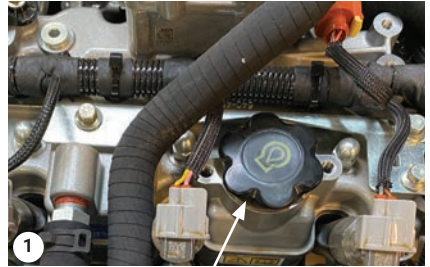

Engine oil filler cap



Oil drain plug



Engine oil filter

Service and maintenance

3.2 Engine oil - continued



Attention

To avoid damage to the crankshaft bearing, the fuse for fuel pump must be removed before cranking the engine.

This will fill the oil filters, before the engine is started. Do not crank the engine for more than 30 seconds. Then insert the fuse and start at idle speed for 2 minutes.

10. Start the engine and run the engine at "LOW IDLE" for 2 minutes. Perform this procedure in order to ensure that the lubrication system has oil and that the oil filters are filled. Inspect the oil filter for oil leaks.

11. Stop the engine and allow the oil to drain back to the sump for a minimum of 10 minutes.

12. Take the dipstick out, wipe clean and put back.

13. Take the dipstick out again to read the oil level.

14. The oil level must be between MAX. and MIN. on the dipstick. (Picture 1)

15. In case of lack of oil, remove the filler cap on the engine. Add oil, wait a few minutes and check the level again.

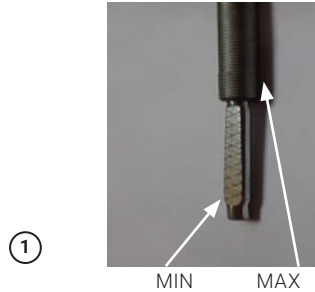

Right side cover

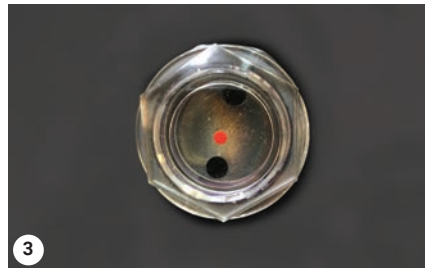

3.3 Hydraulic oil

Checking the hydraulic oil level

1. The hydraulic oil must be checked when it is cold. The oil must be visible in the sight glass. If the oil is not visible it should be topped-up. (Picture 3)

2. If necessary fill the hydraulic oil tank. Dismount right side cover. Unscrew the cap, and pour in hydraulic oil while observing the level glass. (Picture 2+4)

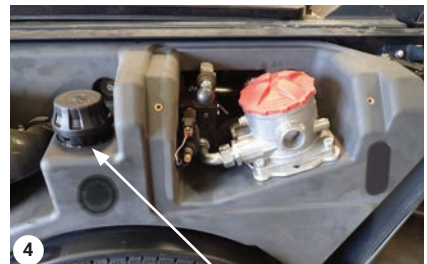

Hydraulic filling cap

Service and maintenance

3.3 Hydraulic oil - continued

Change of hydraulic oil

1. Park the City Ranger 3070 on a level/even surface.

2. Remove the oil drain plug in order to allow the oil to drain in a drain pan. (Picture 1+2)

3. After drainage, clean the oil drain plug and put them back with new gasket.

4. To refill the hydraulic oil tank, unscrew the cap and pour in hydraulic oil while observing the level glass.



Attention

Only use new and correct hydraulic oil.



Attention

Used oil is to be delivered at an approved waste disposal facility or site.

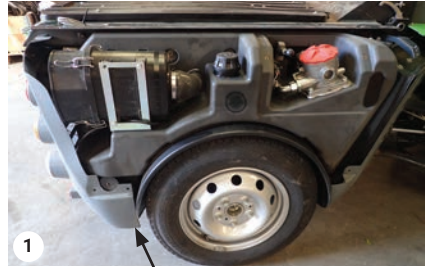

Hydraulic oil drain plug



Hydraulic oil drain plug

Service and maintenance

3.4 Coolant

Recommended coolants

The following two coolants can be used:

- Preferred: Perkins Extended Life Coolant (ELC).
- Acceptable: a commercial heavy-duty coolant that meets "ASTM D6210" specifications.



Attention

Always switch the engine off before topping-up with coolant.



Attention

The coolant line is under pressure. Never remove the cap when the motor is hot as hot water can escape and cause serious burns. Wait for at least ten minutes after the motor has been switched off and then slowly remove the coolant tank cap.

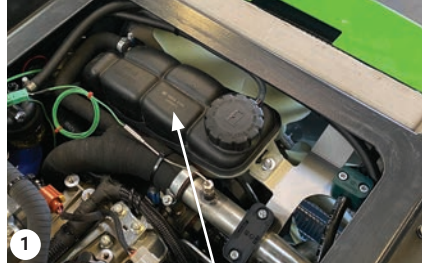

Coolant tank

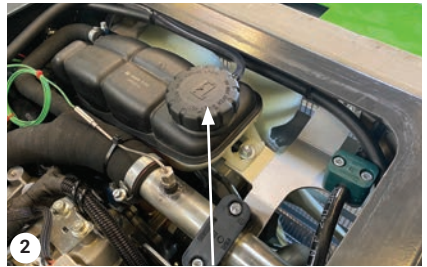

Coolant tank cap

Checking the coolant level

1. The coolant tank is located over the engine fan. (Picture 1)
2. An engine coolant alarm appears if the coolant level is too low. (See section 1.17)
3. To adjust the level, unscrew the coolant tank cap and fill up the coolant tank. (Picture 2)

3.4 Coolant - continued

Coolant replacement



Attention

The coolant line is under pressure; do not perform any check until the engine has cooled down and, even if the engine is cold, the plug of the tank must be opened with extreme care.

1. Prepare a container having a proper capacity (about 16 litres).
2. Drain the cooling system by loosen the drain plug in the bottom of the left hand side radiator. (Picture 1)
3. Drain the coolant in the container, then connect the sleeve.
4. Remove the coolant tank cap (picture 2) and completely fill the system with coolant. The coolant tank must be full.

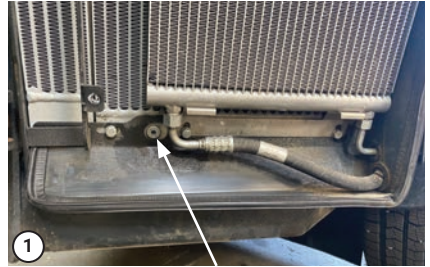

Drain plug

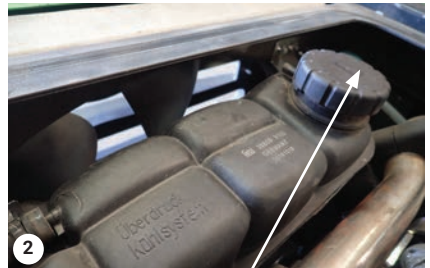

Coolant tank cap

Coolant components

- 50% of ANTIFREEZE.

- 50% of water.

Always use the recommended antifreeze or equivalent.

5. Put back the radiator cap.
6. Turn on the engine and let it idle for a few minutes to reach the operating temperature 70-80°C. If the coolant level alarm appears, top up.



Attention

Hot water.

Service and maintenance

3.5 Brake fluid

Brake fluid used

Type of brake fluid to use: DOT 3 & 4.

Checking the level

1. Look at the brake fluid tank to the left of the steering column. (Picture 1)
2. Check that the brake fluid tank is filled to the Max. mark.
3. To adjust the level, unscrew the cap and add brake fluid. (Picture 2)



Warning

Avoid any contact with brake fluid on skin or eyes. Seek medical attention if contact between eyes and brake fluid happens.



Brakefluid tank



Tank cap

3.6 Windscreen washer liquid

- The windscreen washer tank is located on cabin left side. (Picture 3)
- To add windscreen washer liquid, unscrew the cap.
- Only use washer liquid that have frost protection properties.



Attention

Used Windscreen washer liquid is to be delivered at an approved waste disposal facility or site. (see Section 4.3)



Windscreen washer liquid

Service and maintenance

3.7 Lubrication

Comply with the lubrication intervals.

Lubricant: high performance grease K2C30
DIN 51825.

Grease nipples are located as follows:

Greasing the joints

1. Dry away dirt and old grease from the joint.
2. Apply grease gun and pump until new grease appears from the joint.
3. Remove excess grease.
4. Write down the date and hours of operation for future reference.

All grease points on the vehicle are marked with this sign: 

Recommendation

A grease gun should be stored in near proximity of the machine in order to minimize the chance of lubrication being skipped.

Greasing point number	Description	Acces
1 - 2	A-Frame cylinder right	From underneath
3 - 4	A-Frame cylinder left	From underneath
5	Steering cylinder right front	From underneath
6	Steering cylinder right rear	From right side
7	Steering cylinder left front	From underneath
8	Steering cylinder left rear	From left side
9	A-Frame right	From right side (through hole in wheel)
10	A-Frame left	From left side (through hole in wheel)
11	Articulating joint upper	From side
12	Articulating joint lower	From side
13	Articulating joint	From underneath through hole in rear frame

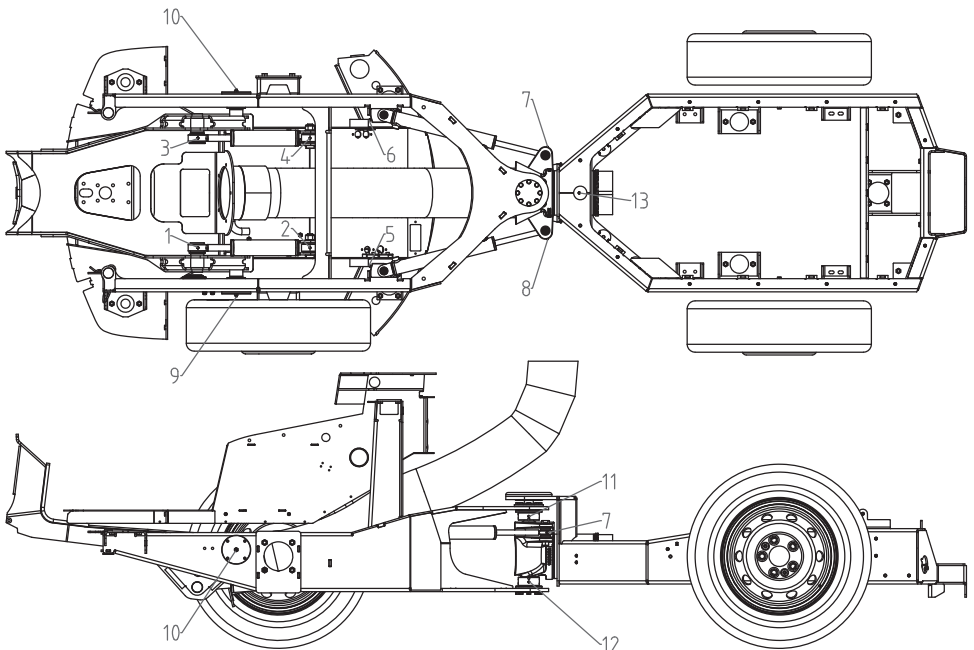

Service and maintenance

3.8 Filters

Hydraulic oil filter

Replace hydraulic filter according to maintenance chart. This task should be performed by authorized service technician. (Picture 1)

Engine air filter

If the clogged air filter symbol appears on the display, the air filter must be changed. (see Section 1.7)

The filter must also be changed according to service maintenance chart.



Warning

Never remove the air filter while the engine is running.

1. Dismount right rear side cover to locate air filter.
2. Loosen the filterhouse and tilt it upwards. (Picture 2)
3. Loosen the straps to retrieve filter elements.

If the air filter is dirty

Remove the primary air cleaner element. (Picture 3)

Clean the inside of the air cleaner cover and body with a clean, dry cloth.

Clean the primary air cleaner element using a vacuum cleaner or low pressure compressed air (pressure < 207kPa). The secondary air cleaner element is not serviceable or washable. (Picture 4)

It should be changed for every three cleanings of the primary air cleaner element. If the primary air cleaner element is damaged, change both elements.

Put back the primary air cleaner element that is new or cleaned. Install the air cleaner cover.



Hydraulic oil filter

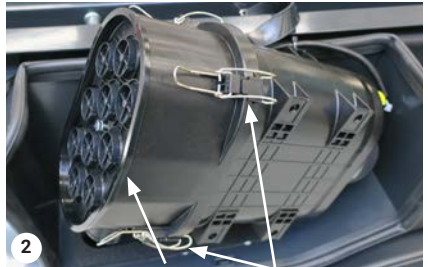

Cyclon prefilter Straps



Primary air cleaner element



Secondary air cleaner element

3.8 Filters - continued

Fuel filter

Replace filter according to maintenance chart. This task should be performed by authorized service technician.

1. Stop the vehicle.
2. Clean the outside of the fuel filter assembly. (Picture 1)
3. Use clamps to block fuel line close to filter to prevent diesel spills.
4. Using a proper tool, remove the filter. Ensure that any fluid is drained into a suitable container.
5. Empty the filter for liquids into a suitable container. The used filter must be disposed of in an environmentally correct way.
6. Check that the seal is in place.
7. Install a new fuel filter.
8. The fuel system will need to be primed after the new filter is installed.
9. Turn the keyswitch to the ON position for 2 minutes in order to prime the fuel system. Turn the keyswitch to OFF position, then turn on again. The engine is primed and ready to start.

①



Fuel filter assy

Service and maintenance

3.8 Filters - continued

Water in fuel check

Check the fuel filter to see if there is water in the fuel circuit. (Picture 1)

If there is water in the fuel, proceed as follows:

1. Turn off the engine and remove the ignition key.
2. Let the engine cool down adequately to avoid being burnt.
3. Prepare a container of appropriate capacity.
4. Unscrew the drain plug located at the base of the fuel filter and leave the fuel to drain out until there is no more water in it. (Picture 2)



Attention

Be careful to ensure that the fuel in the filter does not drain completely out. If it does, remove it, fill it manually and then repeat the bleeding operation.

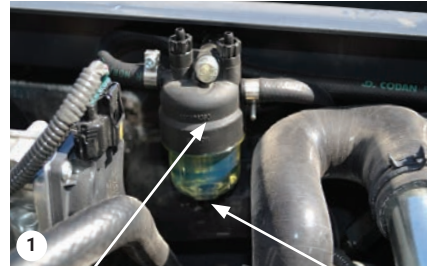

Fuel decanter filter

Drain plug



Container

Filter element

Fuel decanter filter replacement

Check the status of the fuel decanter filter. (Picture 1)

If the element is clogged, proceed as follows.

1. Turn off the engine and remove the ignition key.
2. Let the engine cool down adequately to avoid being burnt.
3. Prepare a container of appropriate capacity.
4. Unscrew the drain plug located at the base of the fuel filter, and empty the filter. (Picture 1)
5. Remove the container. Remove the fuel decanter filter element. Replace it. (Picture 2)
6. Fill the container and put it back. (Picture 1)

Service and maintenance

3.8 Filters - continued

Cabin filter

1. Dismount the cover plate behind the driver's seat by unscrewing the finger screws. (Picture 1+2)
2. Pull out filter.
3. Insert new filter.
4. Mount cover plate.

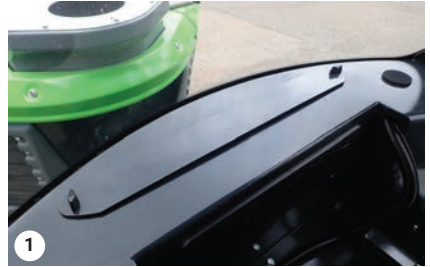

Cabin filter behind seat



Cabin filter behind seat

Recirculation filter

1. Move the driver's seat to its most forward position.
2. The filter is located behind the seat. (Picture 3+4)
3. Unclick the filter and discard it.
4. Click new filter.



Recirculation filter behind seat



Recirculation filter behind seat

Service and maintenance

3.8 Filters - continued

Radiator

1. Stop the vehicle and remove the radiator cover. Check the condition of the radiator. Repeat the check on both side. (Picture 1)

2. If clogged, remove the air conditioning condenser (picture 2) and clean the fins with brush and compressed air (6 Bar). (Picture 2 and 3). Additional put the radiator fan on reverse, see Section 1.7 Alarm lights and monitoring indicators, 1. Error and technical menu, page 23. (Picture 2)

3. If the fins are still clogged, clean them with a brush and kerosene and dry with compressed air (6 Bar). (Picture 2 and 3)

Air conditioning condenser

To ensure the smooth operation of the condenser, regularly clean the air conditioning condenser with a brush or an air compressor gun.

1. Clean the fins with compressed air (6 Bar). If necessary, point the compressed air in the opposite direction of the cooling air. (Picture 4)

If not possible to clean:
call your Egholm after sales service team.



Access to radiator and air conditioning condenser



Brush radiator



Compressed air radiator



Air conditioning condenser

3.9 Checking belts

To maximize the engine performance, inspect the belt for wear and for cracking. Replace a belt that is worn or damaged. If a belt is too loose, vibration causes unnecessary wear on the belt and pulleys. Loose belts may slip enough to cause overheating.

To accurately check the belt tension, a suitable gauge should be used. Install the gauge at the center of the belt between the alternator/compressor and the crank-shaft pulley and check the belt tension. The correct tension for a new belt is 400 N to 489 N. The correct tension for a used belt that has been in operation for 30 minutes or more at the rated speed is 267 N to 356 N. (Picture 1)

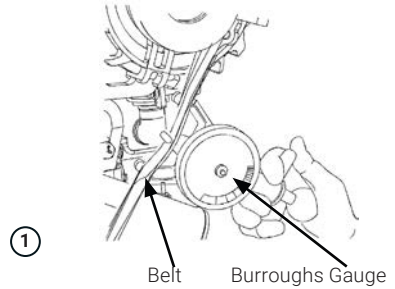

Alternator and water pump belt

Check the belt for wear and tear, also check that it is properly tensioned. (Picture 2)



Alternator belt

Air conditioning belt

Check the belt for wear and tear, also check that it is properly tensioned. (Picture 3)

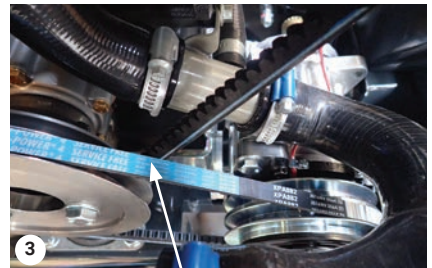

Air conditioning belt

Service and maintenance

3.10 Changing a wheel



Attention

Operate on level and stable ground. The engine must be stopped and the parking brake activated.

To carry out this operation, you require a jack able to support two tones and a spare wheel with a new tyre.

1. Chock the wheel opposite to the wheel to be lifted.
2. Place the jack under the axle closest to the wheel to be changed, in contact with the axle body (point opposite to the arrow). (Picture 1)
3. Once the jack is well positioned, loosen the wheel bolts.
4. Raise the jack until the wheel is a few centimetres above the ground. Watch out the vehicle stability when raising.
5. Unscrew and change the wheel. Screw the bolts but do not tighten.
6. Lower the jack and then tighten the wheel bolts to torque 120 Nm.



Attention

After 20 hours of use, tighten the wheel bolts again to 120 Nm. Wheel bolts should not be lubricated.



Attention

Only use tyre dimension and tyre pressure as specified in section 1.4 page 12.



Attention

Changing tyres on rims may only be carried out at an authorized workshop.



Lifting point

Service and maintenance

3.11 Checking for worn brakes

Both front tires need to be removed. The brake lining can be inspected through the inspection holes in the brake drums. If the lining is worn the brake shoes need to be replaced.

3.12 In case of failure



Attention

Since the City Ranger 3070 is a vehicle with a hydrostatic transmission, it must not be towed more than a few metres, enough to move it out of traffic.

When working on the vehicle, stop the engine, remove the ignition key and pull the parking brake. It is also advisable to check the wheels.

Call your after-sales service and provide the serial number of your City Ranger 3070. You can read it on the information plate of your vehicle.

(Picture 1+2)

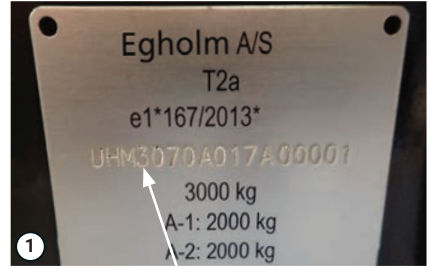

Serial number



Information plate location

3.13 Storage

If long term storage is needed make sure to:

- Clean the machine.
- Drain fuel tank.
- Turn main switch to off position.
- Always store in a dry environment.
- Make sure normal maintenance has been carried out prior to storage.

After storage

- Fill the fuel tank with fresh diesel.
- Turn on the main switch.
- Inspect the machine for damage or other issues.
- Check and test the brakes.
- Air pressure in the tyres.

Service and maintenance

3.14 Valve Calibration

Due to some deviance on the PTO valves, from one machine to another. This calibration can help with getting closer to the behaviour on your tools as it was intended from Egholm. All that is needed is a manometer connected to either measuring point M4 or M5.

The calibration should only be done by authorized personnel in a workshop. Changing the calibration values can have a big impact on how tools are behaving.

Make sure that NO attachments are connected when performing the calibration.

Turn off the machine completely when connecting the Manometer.
(Picture 1+2)

It is recommended that you do this procedure, with a machine that is cold before you start.

Press and hold: "hold to heat", until the temperature is above 60 degrees celcius.

Choose the PTO you are going to calibrate.
(Picture 3)

Find the lowest value were the PTO pressure stabilizes just above 200 bar, start low and go upwards. The calibration value goes from -125 to 125 (-12,5% to 12,5%)

When leaving the page, the current value is saved.



①

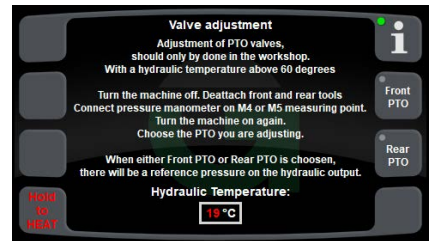

②

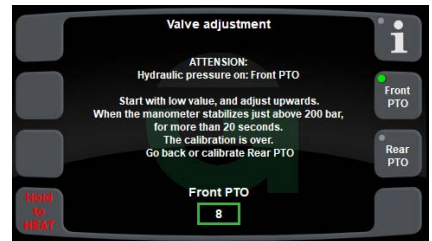

③

Conditions

**Honest
Machines**



Conditions

4.1 Warranty

The warranty period of this City Ranger 3070 is valid from the date of purchase and mandatory filled out Start-up Warranty form. For more information, take contact to the Regional Sales Manager of Egholm.

In case of errors or defects on the machine within the warranty period, the CCS system should be used to report the issues. Egholm will analyze and look into each situation. If instructions are correctly followed and misuse, incorrect or improper use is not the case, Egholm will carry out the necessary repairs without charge for materials and working hours in accordance with the terms and conditions listed below.

The scope of the warranty

1. The Egholm warranty is only valid on presentation of the original receipt, supplied with model description, serial number and date of purchase.
2. Regular checks, adjustments, services and technical alterations are not covered by the warranty.
3. All inquiries concerning the warranty are to be addressed to the distributor from whom the machine was purchased.
4. This warranty does not cover faults and defects which cannot be traced back to defects in material or production errors.
5. This warranty is valid for persons who have legally acquired the machine within the warranty period.
6. In the event of failure to perform and substantiate service in accordance with the applicable instructions, Egholm reserves the right to reject any claim made within the warranty period.
7. Egholm reserves the right to make improvements and design-related alterations to the machine without being obliged to modify previously delivered models in relation hereto.

The warranty does not cover

- Wear and tear, accidents, damage to the equipment caused by operating errors, changes to the construction of the machine or use of non-Egholm spare parts or attachments.
- Machines with illegible serial numbers.
- Damage caused by force majeure such as lightning, flood, fire, war, civil disturbance, etc. or other causes over which Egholm Division has no control.

4.2 Complaints

All inquiries regarding the machine should be made at the distributor from whom the machine was purchased, whereafter the complaint system is applicable. This applies to inquiries concerning normal use, service, maintenance and spare parts as well as any complaints.

We wish you many years of safe and satisfactory use of your machine.

Best regards
Egholm A/S

4.3 Disposal

When, many years from now, your City Ranger 3070 has reached the end of its working life, it should be disposed of in a responsible manner that conforms to relevant disposal regulations.

1. Used hydraulic oil, motor oil, diesel oil, coolant and AC coolant are to be delivered at an approved waste disposal facility or site.
2. Remove the plastic and rubber parts and dispose of them in accordance with the applicable environmental legislation.
3. After the parts mentioned have been removed, the machine is ready to be handed over to one of your local approved scrap merchants.

Honest Work.

Egholm A/S
Transportvej 27
7620 Lemvig, Denmark
T.: +45 97 81 12 05
www.egholm.eu - info@egholm.dk