

**EGHOLM**

# OPERATORS MANUAL

## Egholm 2100 Basic Unit



**EGHOLM** *2100*

# INTRODUCTION

**Dear customer**

## **Thank you for buying an Egholm product**

The Egholm 2100 is a Danish designed and manufactured utility machine that fully satisfies the current demands for quality, functionality, flexibility and easy maintenance.

## **Optimal performance of your Egholm 2100**

Please read this manual carefully to learn how to operate and service your machine correctly. Failure to do so could lead to personal injury or damage to the equipment.

Right-hand and left-hand sides are determined by facing in the direction of forward travel.



### **Safety information**

This is a special message symbol. When you come across this symbol in this manual, be attentive to potential safety concerns, machine damage as well as helpful operating information. Follow the recommended precautions and safe operation practices. Pay particular attention to the paragraphs 1.1 Safety and 3 Maintenance.

This manual should be considered a permanent part of your machine and should remain with the machine when you sell it.

### **Reservations:**

It is the Egholm policy to make continued improvements. We therefore reserve the right to alter the specifications and the equipment of the machine at any time. We make reservations for errors and omissions in this manual.

### **Contact us:**

For questions of any kind regarding your new Egholm product do not hesitate to contact Egholm Maskiner A/S.

Best regards

**Egholm Maskiner A/S**

# CONTENTS

<b>1. General information</b>		<b>Page:</b>
1.1	Safety . . . . .	4
1.2	Technical data . . . . .	6
<b>Basic operation</b>		
1.3	Control panel . . . . .	8
1.4	Fuses . . . . .	8
1.5	Control levers and pedals . . . . .	9
1.6	Detachable platform . . . . .	11
1.7	Drivers seat . . . . .	12
1.8	Oil cooler screen . . . . .	12
<b>2. Instructions for use</b>		
2.1	Daily check before start-up . . . . .	13
2.2	Start-up, driving, and stopping . . . . .	15
<b>3. Service and maintenance</b>		
3.1	Daily maintenance . . . . .	17
3.2	Service and maintenance chart . . . . .	18
3.3	Lubrication . . . . .	20
3.4	Hydraulic system . . . . .	21
3.5	Engine maintenance . . . . .	22
3.6	Fuel . . . . .	24
3.7	Radiator . . . . .	26
3.8	Air filter . . . . .	28
3.9	Battery . . . . .	28
3.10	Fan belt . . . . .	29
3.11	Oil cooler . . . . .	29
3.12	Conditions of warranty . . . . .	30
3.13	Conditions of complaint . . . . .	31
3.14	Disposal . . . . .	31
3.15	EU Declaration of Conformity . . . . .	32

**Also refer to the instruction manual for the engine.**

# 1. GENERAL INFORMATION

## 1.1 Safety



**Keep a safe distance to the articulation point**



**Turn the steering wheel carefully**

Egholm 2100 is an articulated machine and has a very sensitive steering.



**Avoid acid burns and battery explosions**

Batteries contain acid, which can cause severe burns, and fumes that can explode. Handle with great caution!



**Avoid exhaust gas poisoning**

Motor vehicle exhaust gas can cause symptoms like headache, nausea, dizziness, or in worst case be fatal when inhaled in sufficient quantities. Do not idle the vehicle in an unventilated garage or other confined space. Lead the exhaust gas away through an exhaust hose or open doors and windows fully before starting the engine, to prevent a build-up of exhaust gas.



**Avoid accidents caused by tipping**

Do not run the machine where it may slide or tip over. Do not run the machine on slopes or inclines exceeding 10%.



**Keep children in a safe distance when the machine is in operation.**



Machine left side

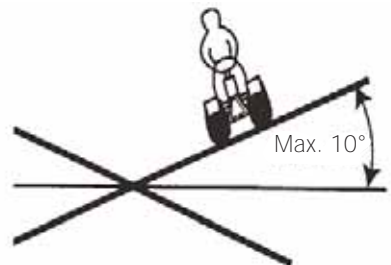
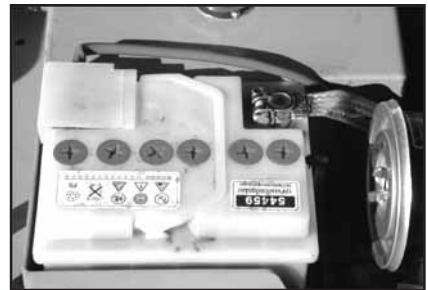
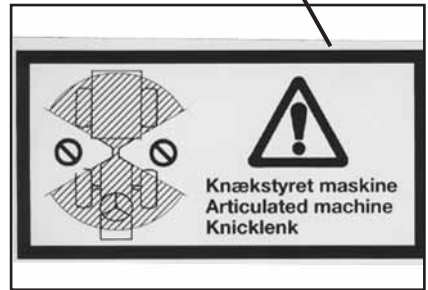

# 1. GENERAL INFORMATION

## Beware of pinch points

Make sure to keep hands and fingers clear of pinch points.



## A-Frame

Avoid getting your fingers caught in the A-frame.

## Exhaust pipe

The exhaust pipe becomes very hot when the machine is running. Avoid contact.



## Fan belt

Make sure to keep fingers clear of ventilating fan and fan belt.



# 1. GENERAL INFORMATION

## 1.2 Technical Data

### Dimensions basic unit:

Length:	2.215 mm
Width:	1.015 mm
Height:	1.210 mm
Height with cab:	1.935 mm
Height with suction unit without cabin:	1.750 mm

### Weight:

Own weight Egholm 2100:	485 kg
Max. allowable load for:	
Platform:	100 kg
Machine complete with trailer:	1.300 kg
Trailer unbraked:	1.300 kg
Allowable axle load, front:	740 kg
Allowable axle load, rear:	740 kg

### Tyre:

Tyre size:	18 x 9.5-8
Tyre pressure:	11.4 bar equal 0.43 kg/cm <sup>2</sup> or 24 PSI

### Engine:

Engine type:	Kubota Diesel
Type no.:	D 722-E
Engine performance:	20.9 HP or 14.0 kW at 3,600 rpm
Cylinders:	3

For further technical information about the engine, please refer to the Kubota instruction manual.

### Fuel:

	Diesel
Fuel tank volume:	20 l diesel
Fuel consumption:	At 2,400 rpm approx. 3 l/h At 3,600 rpm approx. 3½ l/h

### Lubrication system:

	Forced-feed system with filter
Lubricant:	Engine oil: approx 2.7 l - 15W/40 over CC quality
Air filter:	Dry, replaceable element
Cooling system:	Water-cooled

### Electrical system:

Starting system:	Electric start - with hot tube
Charging system:	AC generator
Charging capacity:	12 volt - 35 A



Side view



Egholm 2100 front view

# 1. GENERAL INFORMATION

Battery: 12 volt, 44 AH lead-acid battery

Hydraulic oil: Texaco Rando HDZ 46

Brakes: Mechanical

## Sound measurements:

Pass-by, Directive 74/151 77 dB(A)

Machine operator position 77/311 88 dB(A)

## Note:

The specifications are subject to change without prior notice.

## Turning radius

The Egholm has a turning radius of only 1.5 m.

## Type plate:

The type plate is placed on the front chassis right side.

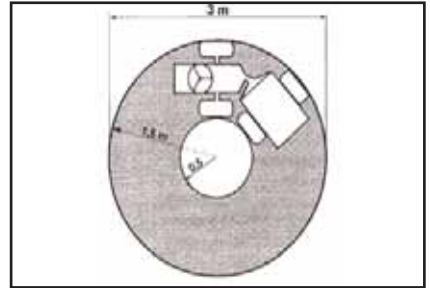

Turning radius



Type plate

# 1. GENERAL INFORMATION

## 1.3 Control Panel

### Low fuel light indicator

Illuminates at a remaining fuel level of 5 l = approx. 1½ operating hours. The light indicator is only active when the engine is turned on.

### Hazard warning flasher

Optional

### Hour meter

### Charger light indicator

Illuminates during ignition and at start-up. When the charger light indicator illuminates at any other time, stop the engine and identify the cause.

### Pre-heater indicator light

Illuminates only when preheating. When the light goes out, turn the key further to start the engine.

## 1.4. Fuses

- A) 7.5 A Charging light
- B) 15 A Fan for oil cooler. Safety network (system). Shut off solenoid valve. Position light.
- C) 15 A light indicators, horn, tank gauge
- D) 15 A Electric tap (trailer)
- E) 15 A Cab, blinkers, lights
- F) 60 A Main fuse (placed under the bonnet, next to the generator)

### Main switch

To start the engine the main switch must be in position ON.

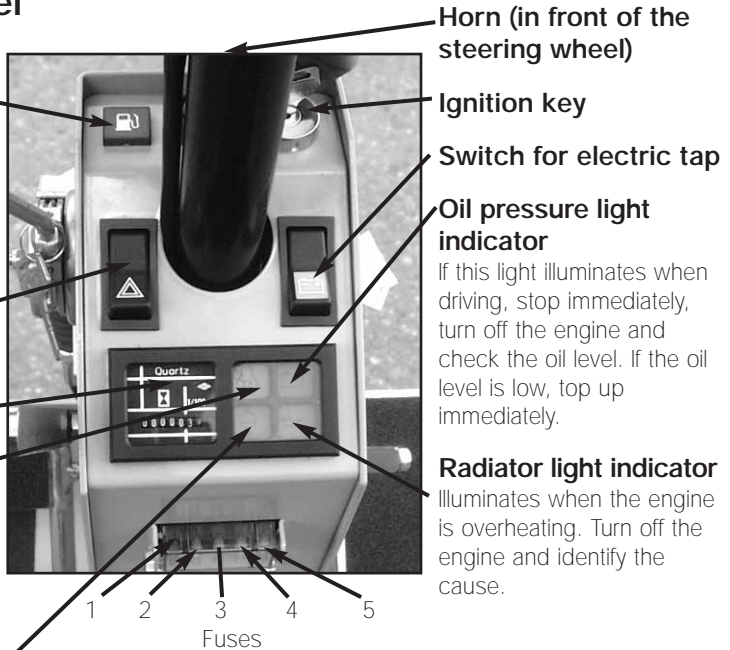

Horn (in front of the steering wheel)

Ignition key

Switch for electric tap

Oil pressure light indicator

If this light illuminates when driving, stop immediately, turn off the engine and check the oil level. If the oil level is low, top up immediately.

Radiator light indicator

Illuminates when the engine is overheating. Turn off the engine and identify the cause.

Fuses

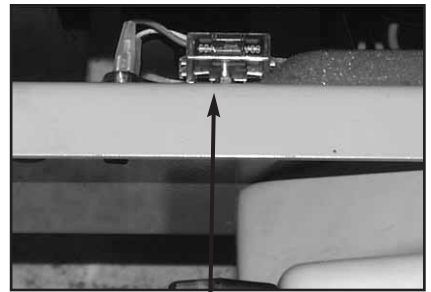

Main fuse

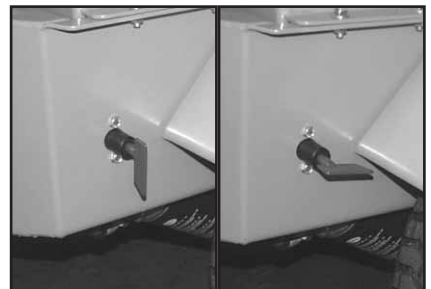

Main switch ON / OFF



# 1. GENERAL INFORMATION

## 1.5 Control levers and pedals

### Lever A:

Raising and lowering of A-frame:

Pos. 1 (upwards): Raises the A-frame.

Pos. 0 (neutral): Locks the A-frame in a given position.

Pos. 3 (downwards): Lowers the A-frame.

### Lever B:

Activates the hydraulic couplings B1 and B2 - for attachments:

Pos. 1 (upwards): The oil flow is activated = the attachment is in operation.

Pos. 0 (neutral): Action depends on the attachment.

Pos. 2 (downwards): Operates the attachment in the opposite direction.

### Lever C:

Activates the hydraulic couplings C1 and C2 for rear-mounted attachments:

Pos. 1 (upwards): Raises the attachment.

Pos. 0 (neutral): Action depends on the attachment.

### Lever D:

Starts the attachment. (Activates the hydraulic couplings D1 and D2):

Pos. 1 (upwards): Activates the attachment.

Pos. 0 (neutral): Deactivates the attachment.

Pos. 2 (downwards): Operates the attachment in the opposite direction.

Hydraulic coupling D3:

Flow connector for various attachments (female ¼")



### Important!

Keep the hydraulic quick couplings free from dirt.

### Activating attachments from outside the cab - only for the remote vac hose

- Park the machine with the parking brake **locked**.
- Press the button for conscious activating of attachments (\*) while activating lever D.

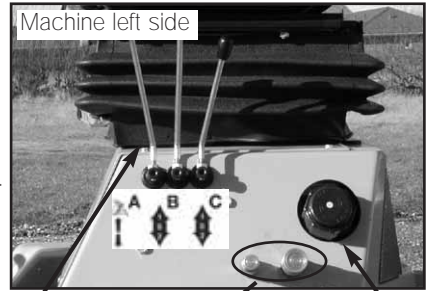

Levers  
A, B, C

Coupling  
B1 og B2

Diesel



A-frame for attachments

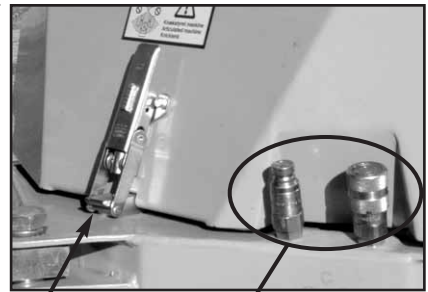

Bonnet lock

Coupling C1 og C2

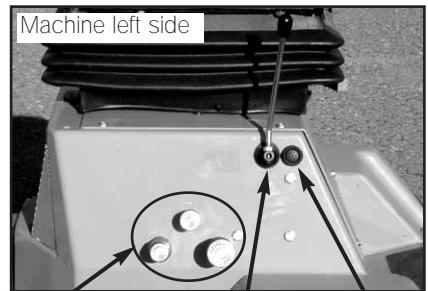

Coupling  
D1, D2, D3

Lever D

Contact (\*)

# 1. GENERAL INFORMATION

## Control levers and pedals

Throttle hand lever  
Parking brake  
Driving pedal  
Brake pedal



Control levers

## Throttle hand lever

Set the throttle hand lever in  $\frac{1}{4}$  throttle position before starting the engine.

## Parking brake

Engaging the parking brake: Fully depress the brake pedal before pushing the parking brake forwards. Release the brake pedal to engage the parking brake.

## Brake pedal

Engaged when depressed.

## Drive pedal

Using the drive pedal requires the brake pedal to be un-braked. The speed control is stepless.

For:

Forwards drive - press the pedal forwards.

Stopping - leave the pedal in middle position.

Reverse drive - press the pedal backwards.

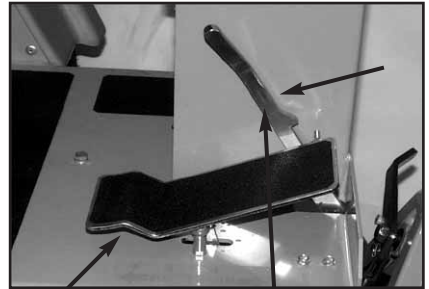

Drive pedal Transport lock disengaged

## Transport lock

The transport lock is always to be disengaged when attachments are activated.

The transport lock is always to be engaged during transport.

The transport lock secures the A-frame in order to avoid lowering of the A-frame during transport and locks the drive pedal to ensure the machine against reverse drive.

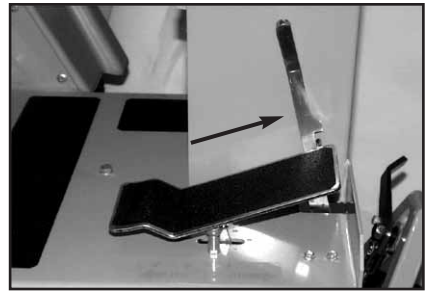

Transport lock engaged

# 1. GENERAL INFORMATION

## Towing handle

Use the towing handle for moving the machine manually.

When the towing handle is **unlocked**, the machine can be moved without starting the engine. Leave the towing handle in horizontal position to unlock.



### Warning!

The power steering is disabled when the towing handle is unlocked.

Driving with the machine is only possible when the towing handle is **locked**. Always lock the towing handle before starting the engine. The towing handle is locked when left in vertical position.

The towing handle is found under the rear chassis, mounted on the transmission pump.

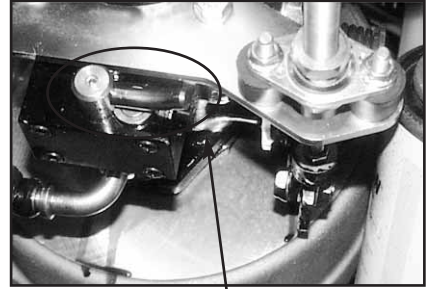

Towing handle is unlocked

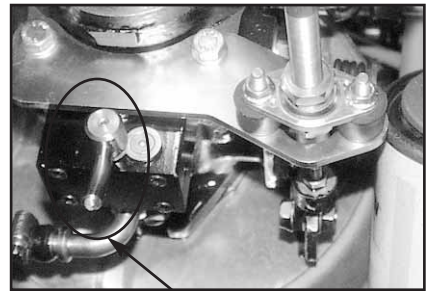

Towing handle is locked

## 1.6 Detachable platform

- |                      |                      |
|----------------------|----------------------|
| 1) Standard platform | 2) Centring fittings |
| 3) Lock bracket      | 4) Mounting frame    |
| 5) Lock eye          | 6) Lock handle       |
| 7) Spring            | 8) Dowel             |

### Dismounting the platform

- Pull out the lock handle and turn it to the right to unlock the platform.
- Pull the platform backwards.

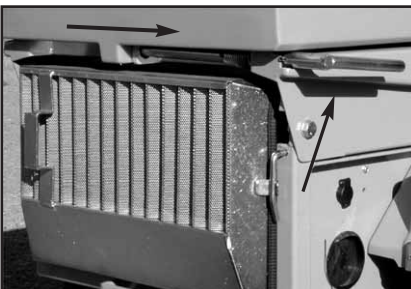

Lock handle in unlocked position

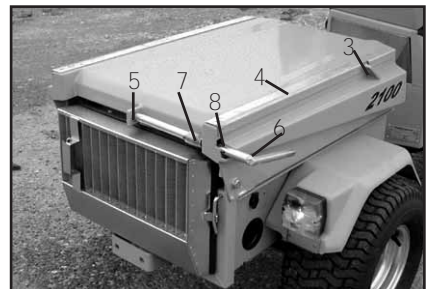

Mounting frame

# 1. GENERAL INFORMATION

## Mounting the platform

- A) Mount the platform from behind and push it into the lock brackets on the mounting frame.
- B) Pull out the lock handle and turn it to the left while pushing it into place.
- C) Make sure that the lock handle is correctly fit in the lock eye. Pull the platform to make sure that it is locked.

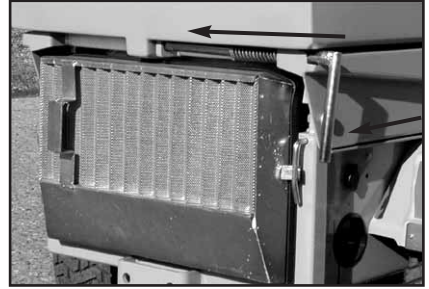

Lock handle in locked position

## 1.7 Drivers seat

Adjust the driver's seat to match the driver.

- |                     |          |
|---------------------|----------|
| Height adjustment:  | Handle 1 |
| Weight adjustment:  | Handle 2 |
| Forwards/backwards: | Handle 3 |



Adjustment of the driver's seat

## 1.8 Oil cooler screen

### Dismounting

Pull the oil cooler screen slantingly downwards to dismount.

### Mounting

- A) Fit the upper edge of the oil cooler screen under the edge of the Egholm 2100.
- B) Push the oil cooler screen into place.

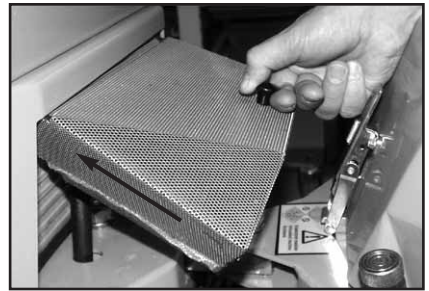

Fitting the oil cooler screen

## 2. INSTRUCTIONS FOR USE

### 2.1 Daily check before start-up

Before performing the daily check open the bonnet:

- A) Dismount the platform (refer to paragraph 1.6).
- B) Remove the radiator screen (refer to paragraph 3.2).
- C) Press the lock knob (1) down and open the lock fittings (2) to unlock the bonnet.
- D) Open the bonnet.

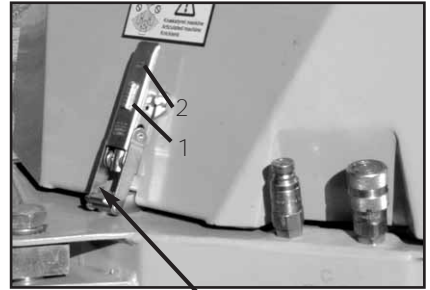

Bonnet lock

#### Important before starting:

#### Check the hydraulic oil

The hydraulic oil must be visible in the sight glass.  
Fortop up - refer to paragraph 3.4, Maintenance.

#### Check the engine oil

The oil level must be between the two marks on the dipstick.  
Fortop up - refer to paragraph 3.5.



Hydraulic oil

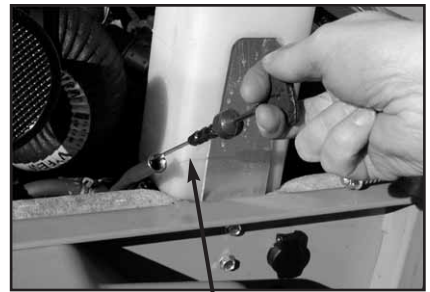

Engine oil

## 2. INSTRUCTIONS FOR USE

### Check the diesel oil

Tank capacity 20 l.

The light indicator illuminates at a remaining fuel level of 5 l = approx. 1½ operating hours.

The light indicator is only active when the engine is turned on.

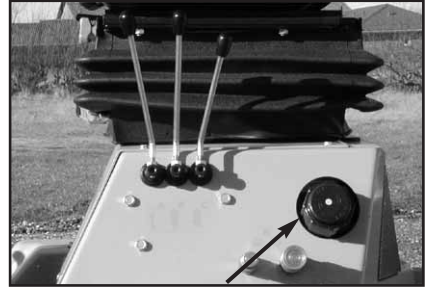

Diesel



Indicator light for diesel oil

### Check the coolant

Remove the radiator cap and check that the coolant level reaches the filling hole.



#### Warning!

Never remove the radiator cap when the engine is hot.

### Check the expansion tank

The level must be between "Full" and "Low".

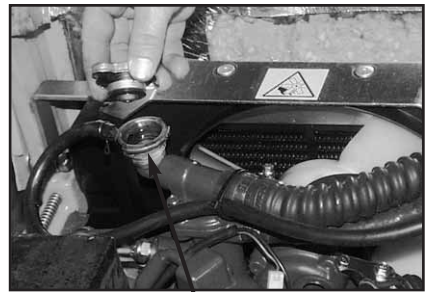

Check the coolant

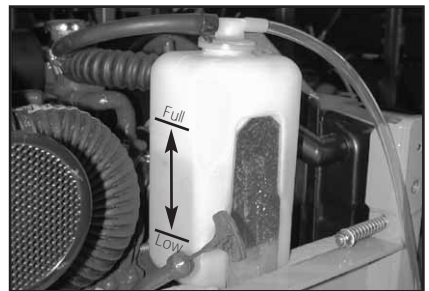

Expansion tank

# 2. INSTRUCTIONS FOR USE

## 2.2 Starting, driving and stopping

The following conditions must be fulfilled before the engine can be started:

- A) The control levers A, B, C and D must be in position "0".
- B) The towing handle must be locked - refer to page 11.
- C) The driver must be in the drivers seat.
- D) Fully depress the brake pedal (1) and release the parking brake (2).
- E) Set the throttle hand lever (3) in ¼ throttle position.



**Warning!**  
For the sake of the hydraulic system it is important to allow the machine to warm up before letting the engine operate at full RPM.

- F) Turn the key (4) until the pre-heater indicator (5) and the other light indicators illuminate. When the pre-heater indicator goes out, turn the key further to start the engine.
- G) Release the brake pedal (1).
- H) The drive pedal (6) is now to be activated  
Forwards drive - press the pedal forwards.  
Stopping - leave the pedal in middle position.  
Reverse drive - press the pedal backwards.

The speed control is stepless.



**Warning!**  
Turn the steering wheel carefully  
Egholm 2100 is an articulated machine and has a very sensitive steering.

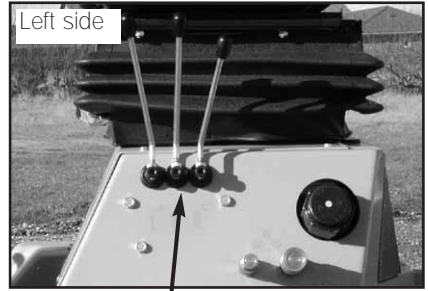

Lever A, B, C

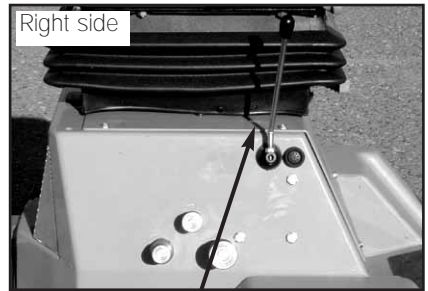

Lever D

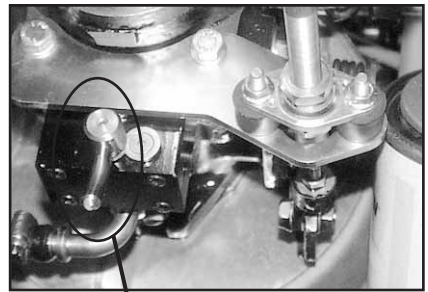

Towing handle is locked

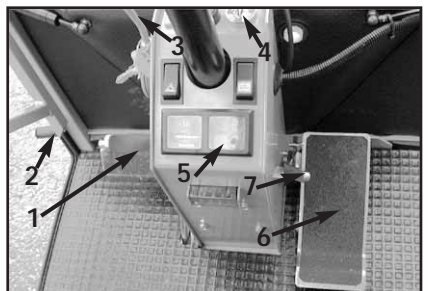

Basic operation

# 2. INSTRUCTIONS FOR USE

## Stopping the Egholm 2100

- A) Leave the control levers A, B, C and D in position "0".
- B) Close the throttle and let the engine idle.
- C) Fully depress the brake pedal (1) and push the parking brake (2) forwards - refer to page 13.
- D) Stop the engine by turning the ignition key back to initial position.

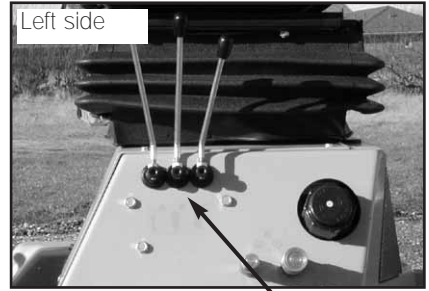

Lever A, B, C

## Driving with front-mounted attachments

Raise the A-frame with possible attachment before driving.

Raise the attachment by pushing lever A upwards into pos. 1. Release lever A when the attachment has reached the required height.

Don't forget to engage the transport lock (7) when driving long distances - refer to page 10.

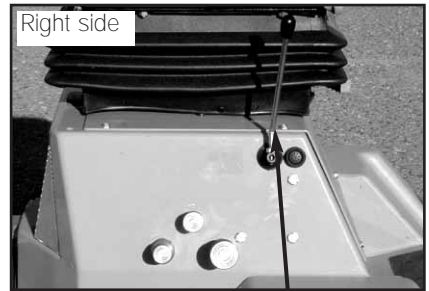

Lever D

## Lever A - Further functions

Push lever A into pos. "0" to lock the A-frame/attachment.

Push lever A downwards into pos. 2 to lower the A-frame/attachment.



A-frame

## Mounting front and rear-mounted attachments

Please refer to the operator's manual for the individual attachments.

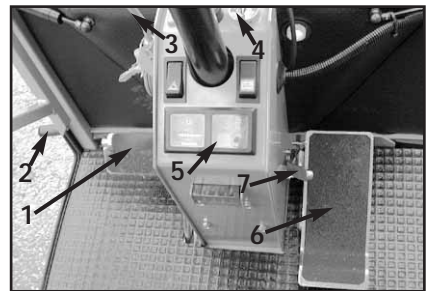

Basic operation



# 3. SERVICE AND MAINTENANCE

## 3.1 Daily maintenance

The daily maintenance of the Egholm 2100 is plain and simple but important. Three things are to be done on a daily basis: Cleaning the radiator, the oil cooler and the air filter.

### Cleaning the radiator

- A) The radiator cover is easily removed by turning the two spring-mounted handles outwards.
- B) Use compressed air to blow dirt off the radiator ribs and screen.
- C) Use clean water to wash the radiator ribs.



#### Warning!

Never use hard tools to clean the radiator core, as these may damage the radiator ribs.

### Cleaning the oil cooler

- A) Remove the oil cooler screen - refer to paragraph 1.8.
- B) Use compressed air to blow dirt off the cooler screen and oil cooler.



#### Warning!

Use compressed air to clean the cooler before washing the machine, or the cooler may become clogged with dirt.

### Air filter housing and air filter element

Clean the air filter housing using a clean cloth. Clean the air filter element from the inside with compressed air - refer to page 27.

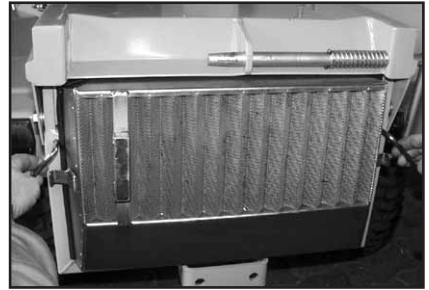

Remove the radiator screen

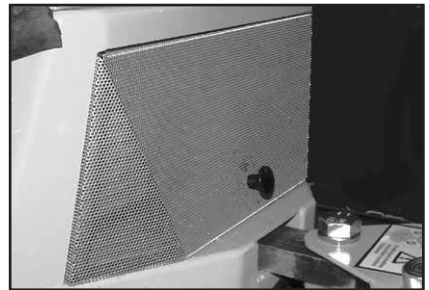

Oil cooler screen



Lift the air filter housing

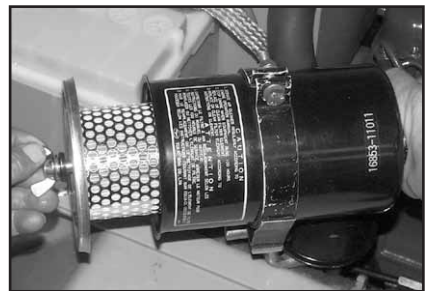

Remove the air filter

# 3. SERVICE AND MAINTENANCE

## 3.2 Service- and maintenance chart

Service		Hour											
		Daily	50	125	200	275	350	425	500	575	650	725	
Engine oil	Inspec.	*											
	Change		*	*	*	*	*	*	*	*	*	*	*
Hydraulic oil	Inspec.	*			*				*				
	Change		*				*				*		
Air filter 1)	Inspec.	*			*				*				
	Change		*				*				*		
Cooling water 2)	Inspec.	*	*		*		*				*		
	Change								*				
Fan belt 3)	Inspec.		*		*		*				*		
	Change								*				
Bearings, articulation point	Inspec.		*				*				*		
Engine oil filter	Change		*		*		*		*		*		
Transmission filter	Change		*				*				*		
Tank filter	Change		*				*				*		
Fuel filter	Change		*				*				*		
Fuel hoses 4)	Inspec.		*				*				*		
Radiator 5)	Clean	*	*		*		*		*		*		
Oil cooler 6)	Clean	*	*		*		*		*		*		
Flow and pressure, hydraulic system	Do		*		*		*		*		*		
Adjusting - pressure control valve	Do		*				*				*		
Thermostat radiator	Inspec.		*				*				*		
Radiator hoses 7)	Inspec.		*				*				*		
Temperature alarm	Inspec.		*	*	*	*	*	*	*	*	*	*	*
Oil level alarm (hydraulic)	Inspec.		*	*	*	*	*	*	*	*	*	*	*
Thermostat oil cooler	Inspec.		*				*				*		
Ventilator oil cooler	Inspec.		*				*				*		
Lubrication A-frame	Do		*		*		*		*		*		
Adjusting - throttle cable	Do		*				*				*		
Adjusting - drive cable	Do		*				*				*		
Control brakes	Inspec.		*				*				*		
Battery 8)	Inspec.		*		*		*		*		*		
Tyre pressure	Inspec.		*		*		*		*		*		
Light and mirrors	Inspec.	*	*		*		*		*		*		
Electric system	Inspec.		*		*		*		*		*		
Adjustment - valves	Do												
Adjustment - jets	Do												

1. More frequent maintenance is required when working in severe conditions.

2. Cooling water – replace at least once a year.

3. Fan belt – replace at least once a year.

4. Fuel hoses – replace at least once every two years.



# 3. SERVICE AND MAINTENANCE

## 3.3 Lubrication

### Lubrication nipples:

Lubricate the two lubrication nipples after every 15 hours of operation with one or two blobs of good quality grease. The lubrication nipples can be found on the backside of the A-frame.

### Cables and movable parts

Lubricate with a few drops of oil after every 15 hours of operation.



Lubrication nipples

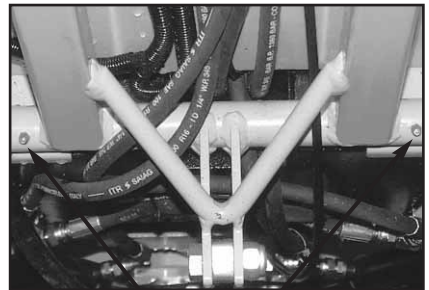

Lubrication nipples

# 3. SERVICE AND MAINTENANCE

## 3.4 Hydraulic system

### Hydraulic oil:

Check the hydraulic oil level only when the oil is cold.  
The oil must be visible in the sight glass.  
Top up if the oil is not visible in the sight glass.



### Warning!

Clean the area around the filler before removing the filler cap to make sure that no dirt enters the hydraulic system, where it may cause damage.

### Top up hydraulic oil

- Park the Egholm 2100 on level ground.
- Turn off the engine.
- Remove the filler cap and add Texaco Rando HDZ 46 oil.
- Replace the filler cap and start the engine.
- Check that the oil covers  $\frac{3}{4}$  of the sight glass.

### Tank filter

Replace the filter and clean the filter housing at every service inspection.



Hydraulic oil



Adding oil



Tank filter



Tank filter housing

# 3. SERVICE AND MAINTENANCE

## Hydraulic oil filter

- A) Remove the oil filter (under the Egholm 2100) to drain the tank.
- B) Lubricate the sealing surface with oil.
- C) Install new oil filter.
- D) Fill the tank with approx. 15 l of Texaco Rando HDZ 46 oil. Check that the oil covers  $\frac{3}{4}$  of the sight glass.



Hydraulic oil filter

## 3.5 Engine maintenance



### Warning!

Always stop the engine before checking the oil level or changing the oil and oil filter.

### Check the engine oil:

- A) Park the Egholm 2100 on level ground.
- B) Check the oil level before starting the engine.
- C) Remove the dipstick, wipe it clean and reinsert it fully.
- D) Remove the dipstick and now read the oil level to make sure that there is enough oil in the engine.
- E) There are two marks on the dipstick. The oil level must be between the upper and lower marking.
- F) If the oil level is below the lower marking, add oil.
- G) Never overfill. Always keep the oil level correct.

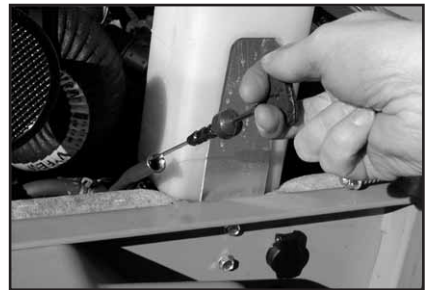

Check the oil

### Top up engine oil

- A) Remove the filler cap.
- B) Top up with 15W/40 oil until the oil level is approx. 2.7 l.
- C) Wait a few minutes for the oil to drain in the oil pan.
- D) Recheck the oil level.

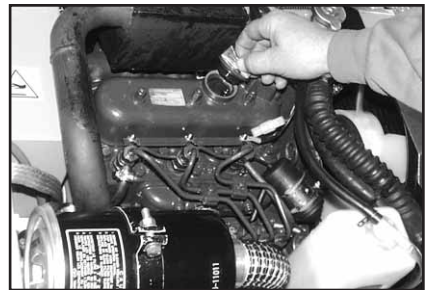

Removing the oil cap



Filling engine oil

# 3. SERVICE AND MAINTENANCE

## Engine oil change

Change the engine oil after the first 50 hours of operation. Oil change is done easier when the engine is hot.

- A) Unscrew the plug on the bottom of your oil pan to drain the oil.
- B) Let it drain completely and replace the plug.
- C) Top up with new engine oil until the oil level reaches the upper marking of the dipstick - approx. 2.7 l 15W/40 oil.

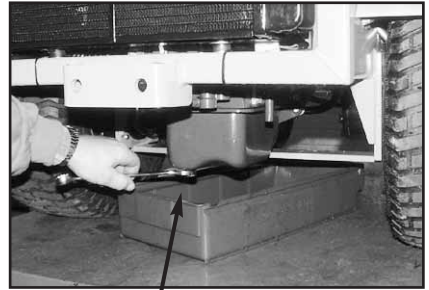

Remove the plug

## Engine oil filter change

- A) Use a special oil filter wrench to remove the oil filter.
- B) Lubricate the sealing surface of the new filter with some oil.
- C) Screw the new filter on by hand.
- D) Do not use the oil filter wrench, as this will overtighten the filter.
- E) Start the engine and let it run a bit to check for any leaks around the filter. If oil is leaking, tighten up the filter some more.
- F) Stop the engine and check the oil level.
- G) Top up if necessary.



Changing the oil filter

# 3. SERVICE AND MAINTENANCE

## 3.6 Fuel



### Warning!

Always stop the engine before filling the fuel tank. Avoid open flames. Diesel fuel oil is flammable.

### Fuel:

Always use diesel oil as fuel.

The tank volume is 20 l. The low fuel light indicator (photo 2) illuminates at a remaining fuel level of 5 l = approx. 1½ operating hours. The light indicator is only active when the engine is turned on.

### Important when filling the tank!

Always use a diesel fuel filter to eliminate impurities and protect the injection pump. Do not let the engine run out of fuel - this will cause air in the fuel system.

### Fuel filter:

- 1) O-ring
- 2) O-ring
- 3) Filter element
- 4) Spring
- 5) Filter glass bowl
- 6) Eye bolt
- 7) Fuel hose
- 8) Hose clip
- 9) Fuel cock

### Cleaning and replacing the fuel filter:

Always clean the fuel filter in clean surroundings.

- A) Close the fuel cock (9).
- B) Remove the filter bowl (5) and flush the inside with fresh diesel fuel.
- C) Replace the filter element (3).
- D) Reassemble the filter - avoid impurities!
- E) Bleed the injection pump.

The fuel filter can be found under the filter housing.

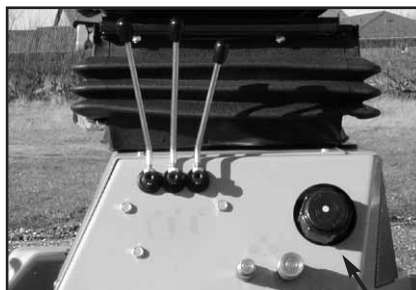

Left side

Diesel



Fuel light indicator

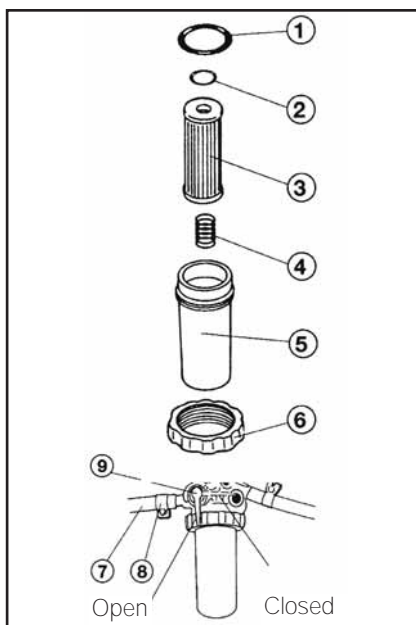

Fuel filter



# 3. SERVICE AND MAINTENANCE

## Bleeding the fuel system

Bleeding the fuel system is necessary if any of the following have occurred:

- A) Replacing fuel filter.
- B) After repairing or replacing any fuel hose.
- C) Running out of fuel.

## Bleeding the fuel system/the injection pump:

- A) Loosen the air bleed screw on the fuel pump and turn the ignition key into starting position until all the air bubbles are out.
- B) When no more bubbles appear, re-tighten the air bleed screw.
- C) Loosen one of the nozzle pipes and turn the ignition key into starting position until all the air bubbles are out.
- D) When no more bubbles appear, re-tighten the nozzle pipe and start the engine.



### Warning!

Never bleed the fuel system when the engine is still hot. Spilling fuel on a hot exhaust manifold can cause fire.



### Warning!

Always stop the engine before checking or replacing fuel hoses. Damaged fuel hoses can cause fire.

## Check the fuel hoses every 50 hours of operation:

- A) Check for loose clamps - lubricate the screw with a little oil and retighten.
- B) Replace any fuel hose or clamp found to be worn or defective.
- C) Bleed the fuel system after replacing fuel hoses.

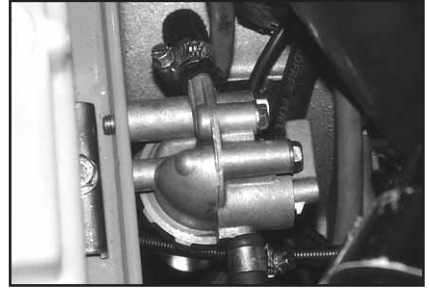

Fuel filter

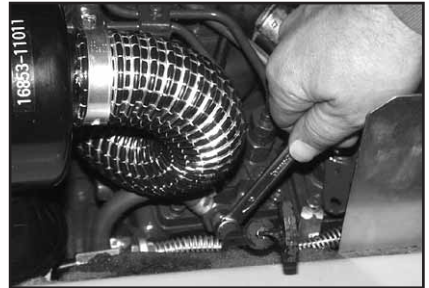

Airbled screw on the fuel pump



Nozzle pipe

# 3. SERVICE AND MAINTENANCE

## 3.7 Radiator



### Warning!

Removing the radiator cap on a hot engine can cause the hot coolant to spray out, seriously scalding you. Always let the engine and radiator cool down before you remove the cap.

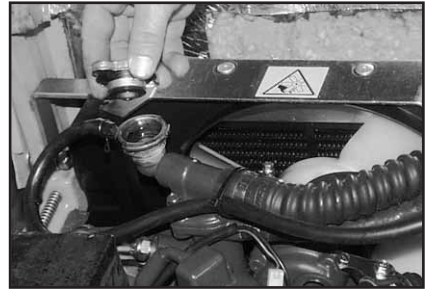

Radiator cap

### Check the coolant level every day:

- A) Remove the radiator cap.
- B) Check every day that the radiator is filled up to base of the filler neck and top up if necessary.

### Check the expansion tank

- A) The level should always be between the FULL and LOW marks on the side of the tank.
- B) Check the level every day and top up if necessary.

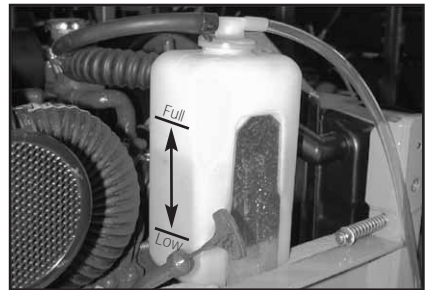

Expansion tank



### Warning!

Always stop the engine before topping up coolant!

### Coolant top up

- A) Remove the radiator cap and fill in approx 4 l coolant mix until the level reaches the FULL mark (do not overfill).
- B) Keep a 50/50 coolant mix (50% pure water and 50% antifreeze) as prescribed on the canister label.
- C) Carefully put the radiator cap back on.
- D) Run the engine until it warms up.
- E) Turn the engine off and let it cool down. After it is cooled down, recheck the coolant level and top up if necessary.



Adding coolant

### Coolant replacement

Please refer to the engine instruction manual, page 16.

## 3. SERVICE AND MAINTENANCE

### Radiator hose replacement

Replace the radiator hoses and hose clips every two years, or sooner if they show any sign of leakage. For further information please refer to the engine instruction manual, page 16.

### Precautions against overheating

Turn off the engine **IMMEDIATELY** if the radiator light indicator illuminates and identify the cause. For further information please refer to the engine instruction manual, page 16.

### Cleaning the radiator

Clean the cooling system according to the service and maintenance schedule, page 18.

For cleaning of the radiator, refer to page 17.

For further information please refer to the engine instruction manual, page 16.

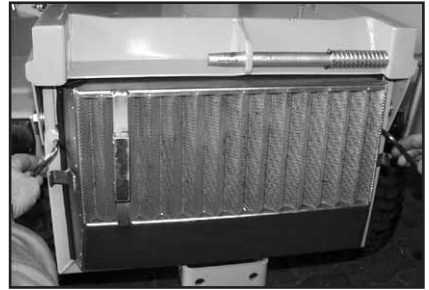

Remove the radiator screen

# 3. SERVICE AND MAINTENANCE

## 3.8 Air filter

### Air filter cleaning:

- A) Open the vacuum valve every day to remove any large particles of dust and dirt, if the Egholm 2100 is operated in dusty conditions.
  - B) Lift the air filter housing 2-3 cm.
  - C) Turn the air filter housing.
  - D) Loosen the wing nut (4) on the air filter.
  - E) Clean the air filter housing with a clean cloth.
  - F) Use compressed air to clean the element from the inside - refer to page 27. The air pressure must not exceed 686 kPa.
  - G) The wing nut must be securely tightened!
- For further information please refer to the engine instruction manual, page 16.

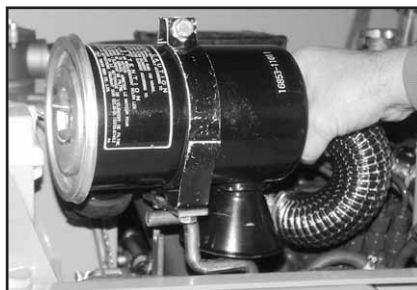

Lift the filter housing

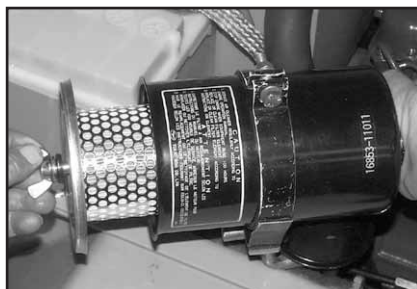

Remove the air filter element

## 3.9 Battery



### Warning!

Always take the following precautions when removing the battery:

- A) Turn off the ignition.
- B) Always remove the negative (-) cable first.
- C) Make sure that no metal tool touches both poles of the battery at the same time, and that the positive (+) pole does not come in contact with the machine at any time. This will cause a short circuit, which generates sparks.
- D) Avoid sparks and open flames. Do not smoke.
- E) When replacing the battery, always connect the positive cable before the negative cable.

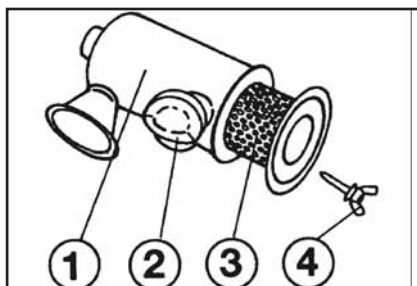

- 1) Air filter housing
- 2) Vacuum valve
- 3) Element
- 4) Wing nut



### Warning!

Batteries contain acid, which can cause severe burns, and fumes that can explode. Handle with great caution!

### Charging

Connect the positive terminal of the charger to the positive pole of the battery and the negative terminal to the negative pole.

### Fluid level

Fill the battery only with distilled water. For further information please refer to the engine instruction manual, page 19.

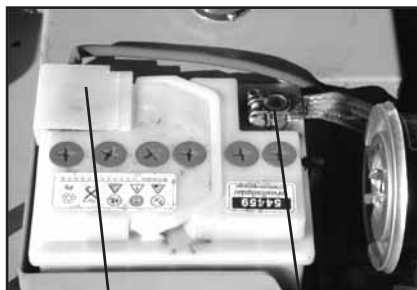

+ Battery -

# 3. SERVICE AND MAINTENANCE

## 3.10 Fan belt

Too loose a fan belt leads to overheating and insufficient charging of the battery.

- A) Check the belt tension by pressing the middle of the fan belt with your finger. A properly tensioned fan belt should deflect 7-9 mm (at a pressure of 10 kgf).
- B) Inspect the fan belt for damage and wear.

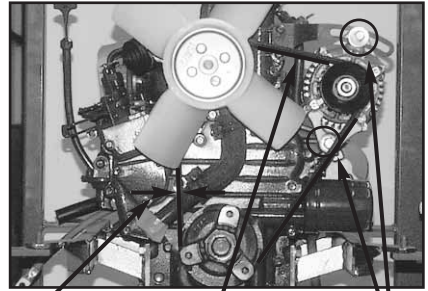

7-9 mm

Fan belt

Bolts

### Fan belt adjustment

Loosen the two bolts that hold the generator and adjust them to achieve a correct tension.

Don't forget to retighten the nuts and bolts after adjustment!



#### Warning!

Keep fingers clear of ventilating fan and fan belt.

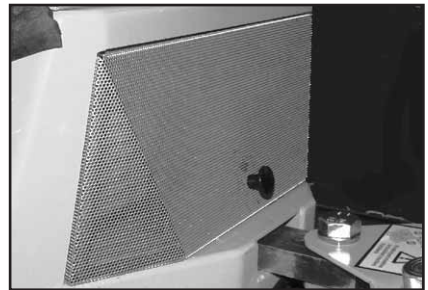

Oil cooler screen

## 3.11 Oil cooler

- A) Remove the oil cooler screen - refer to paragraph 1.8.
- B) Use compressed air to clean the oil cooler screen and the oil cooler.



#### Warning!

Always clean the oil cooler with compressed air before washing the Egholm 2100 with clean water, or the cooler may become clogged with dirt.

# 3. SERVICE AND MAINTENANCE

## 3.12 Conditions of warranty

### The warranty period

The warranty period for the construction parts and the manufacture of this Egholm 2100 unit is 12 months from the date of purchase.

### The scope of warranty

In case of defects on the machine within the warranty period, Egholm Maskiner A/S will - at its own discretion - carry out the necessary repairs without charge for material and working hours according to the terms and conditions listed below. The customer is to cover the costs for transportation.

1. The Egholm warranty is only valid on presentation of the original receipt supplied with model description, serial number and date of purchase.
2. Regular checks, adjustments, services and technical alterations are not covered by the guarantee.
3. All inquiries concerning the warranty are to be addressed to the place where the machine was purchased.
4. This warranty does not cover faults and defects, which cannot be traced back to defects in material or production errors.
5. Egholm Maskiner A/S reserves the right to make improvements and design-related alterations to the machine without being obliged to modify previously delivered models in relation hereto.
6. This warranty is valid for persons who have legally acquired the machine within the warranty period.

### The guarantee does not cover:

- \* Wear and tear, accidents, damage to the equipment caused by operating errors, improper utilization of the machine, constructural changes to the machine or use of non-Egholm spare parts or implements.
- \* Machines with illegible serial number.
- \* Lack of maintenance.
- \* Damages caused by force majeure like lightning, floods, fire, war, civil disturbances etc. or other causes over which Egholm Maskiner A/S has no control.

# 3. SERVICE AND MAINTENANCE

## 3.13 Conditions of complaint

All inquiries regarding the machine or implement should be put forward at the distributor, from whom the machine was purchased. This applies to inquiries concerning normal use, service, maintenance and spare parts as well as to possible complaints.

If there are questions that the distributor cannot answer, please do not hesitate to contact Egholm Maskiner A/S directly. Also feel free to contact us for suggestions or wishes for special implements and/or features for the machine. We wish you many years of safe and satisfied use of your machine.

Best regards  
Egholm Maskiner A/S,  
Transportvej 27,  
DK-7620 Lemvig,  
Tlf. 9781 1205, Fax. 9781 1210  
www.egholm.dk \* Egholm@Egholm.dk

dealer:

## 3.14 Disposal

When - many years from now - your Egholm product comes to the end of its working life, it should be disposed of in a responsible manner and conform with the relevant disposal regulations.

1. Drain all fluids from the Egholm 2100:

A. Diesel oil      B. Hydraulic oil      C. Engine oil      D. Coolant

Refer to the respective paragraph in this operator's manual for detailed information of how to drain the fluids.

Used fluids are to be disposed of at an approved waste disposal facility or site.

2. Remove the battery and hand it over to the local retailer or to the recycling facility for processing.
3. Remove the tyres and hand them over to the local retailer or an approved scrap merchant.
4. Dismount all plastic and rubber parts and discard in a dust bin.
5. After having removed the above mentioned parts, the machine is ready to be handed over to one of your local approved scrap merchants.

# 3. SERVICE AND MAINTENANCE

## 3.15 Declaration of conformity

Egholm Maskiner A/S hereby declares that:

The machine: Egholm 2100

with the serial number: \_\_\_\_\_ Year: \_\_\_\_\_

has been manufactured in conformity with the Council directive (71/221/EEC, 89/392/EEC, 74/150/EEC, 82/890/EEC, 77/311/EEC of 14 June 1989 on the approximation of the laws of the member states relating to machinery, with particular reference to the amending directives 91/368/EEC, 93/44/EEC and 93/68/EEC on material, health and safety requirements in the construction and production of machinery.

Title: Director    Name: Kaj Egholm    Signature: Kaj Egholm    Date: \_\_\_\_\_



# NOTES

# NOTES

# NOTES

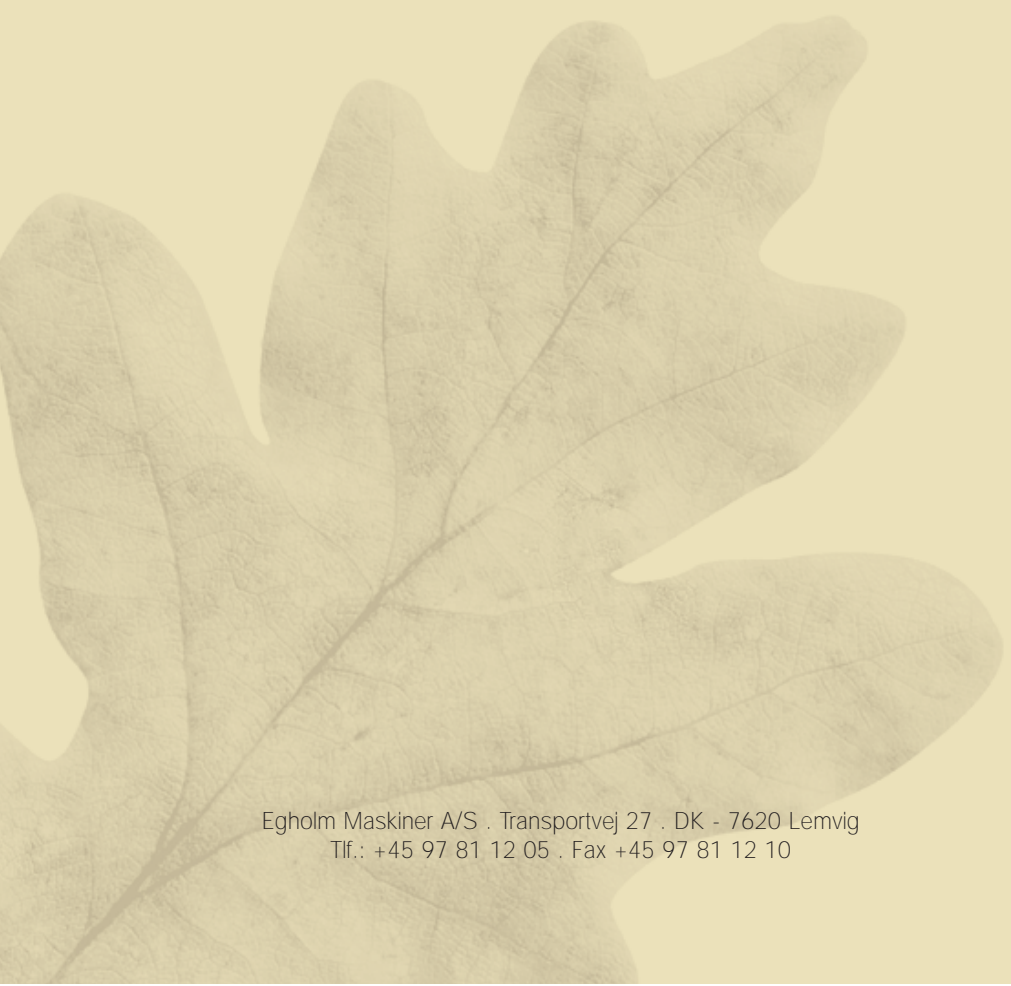

Egholm Maskiner A/S . Transportvej 27 . DK - 7620 Lemvig  
Tlf.: +45 97 81 12 05 . Fax +45 97 81 12 10